

**LUDLUM MODEL 193  
SURVEY METER**

**August 2023**

**Serial Number 323457 and Succeeding  
Serial Numbers**

**LUDLUM MODEL 193  
SURVEY METER**

**August 2023**

**Serial Number 323457 and Succeeding  
Serial Numbers**



**LUDLUM MEASUREMENTS, INC**  
501 OAK STREET, P.O. BOX 810  
SWEETWATER, TEXAS 79556  
325-235-5494, FAX: 325-235-4672

## **STATEMENT OF WARRANTY**

Ludlum Measurements, Inc. warrants the products covered in this manual to be free of defects due to workmanship, material, and design for a period of twelve months from the date of delivery. The calibration of a product is warranted to be within its specified accuracy limits at the time of shipment. In the event of instrument failure, notify Ludlum Measurements to determine if repair, recalibration, or replacement is required.

This warranty excludes the replacement of photomultiplier tubes, G-M and proportional tubes, and scintillation crystals which are broken due to excessive physical abuse or used for purposes other than intended.

There are no warranties, express or implied, including without limitation any implied warranty of merchantability or fitness, which extend beyond the description of the face there of. If the product does not perform as warranted herein, purchaser's sole remedy shall be repair or replacement, at the option of Ludlum Measurements. In no event will Ludlum Measurements be liable for damages, lost revenue, lost wages, or any other incidental or consequential damages, arising from the purchase, use, or inability to use product.

## **RETURN OF GOODS TO MANUFACTURER**

If equipment needs to be returned to Ludlum Measurements, Inc. for repair or calibration, please send to the address below. All shipments should include documentation containing return shipping address, customer name, telephone number, description of service requested, and all other necessary information. Your cooperation will expedite the return of your equipment.

**LUDLUM MEASUREMENTS, INC.  
ATTN: REPAIR DEPARTMENT  
501 OAK STREET  
SWEETWATER, TX 79556**

**800-622-0828 325-235-5494  
FAX 325-235-4672**

REV #	ALTERATIONS	DATE	BY
1	VALID	5-13-97	JGW
2	ECF# 2072	3-15-06	CMC
3	ECF# 2489	6-25-11	CMC

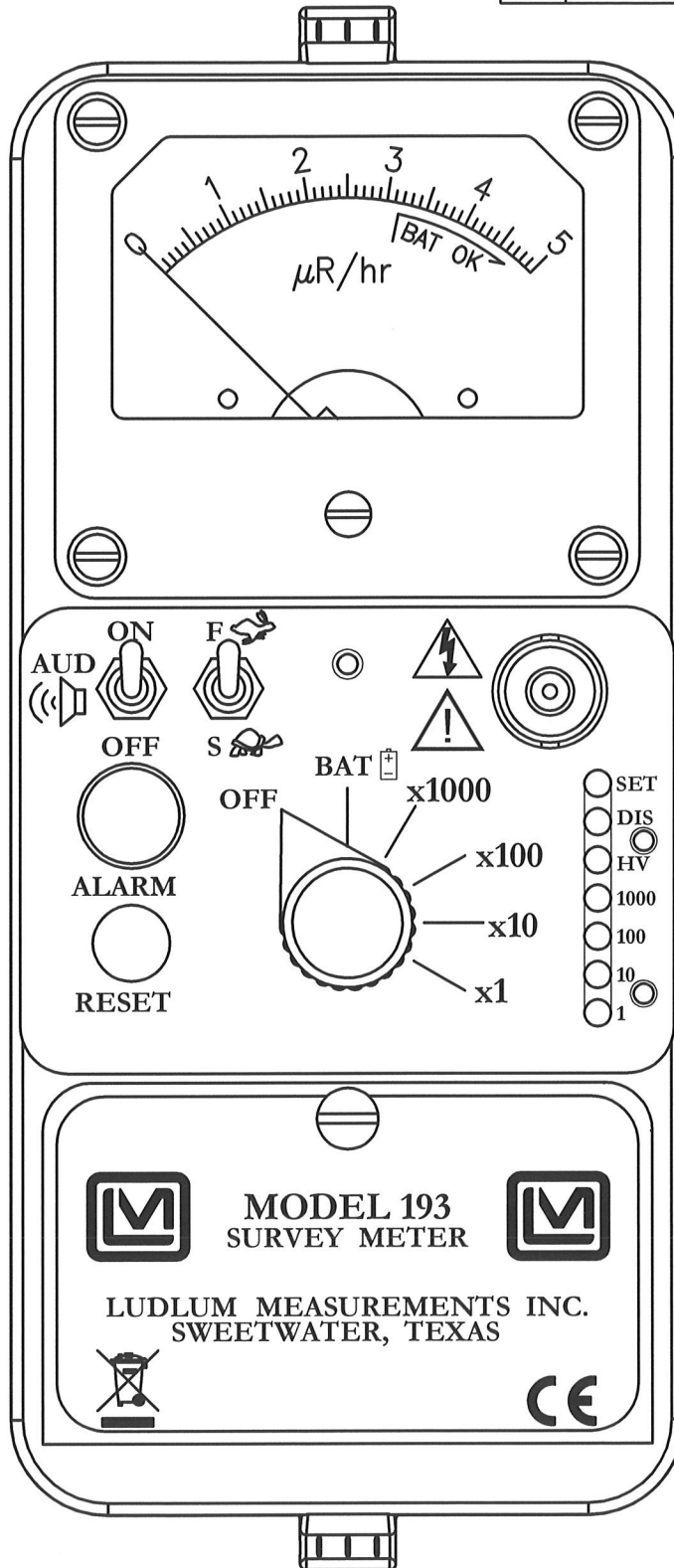

DWN CMC	DATE 6-25-11	CHK	DATE	APP JGW	DATE 6-27-11
PART NUM:				SCALE: <input type="checkbox"/> FULL <input type="checkbox"/> OTHER	
TITLE M 193 FRONT PANEL DRAWING					
LUDLUM MEASUREMENTS, INC. 501 DAK STREET SWEETWATER, TEXAS 79556			SERIES 363	SHEET 772	

# Table of Contents

---

<b><i>Introduction</i></b>	<b><i>1</i></b>
<b><i>Getting Started</i></b>	<b><i>2</i></b>
Unpacking and Repacking	2-1
Battery Installation	2-1
Connecting a Detector to the Instrument	2-2
Battery Test	2-2
Operational Check	2-2
Surveying for Radiation	2-4
Background and Manmade Radiation	2-4
Radiation Limits	2-5
Suggested Survey Technique	2-5
Range Selector and Actual Measurement	2-5
False Alarms	2-6
<b><i>Specifications</i></b>	<b><i>3</i></b>
<b><i>Identification of Controls and Functions</i></b>	<b><i>4</i></b>
<b><i>Safety Considerations</i></b>	<b><i>5</i></b>
Environmental Conditions for Normal Use	5-1
Warning Markings and Symbols	5-1
Cleaning and Maintenance Precautions	5-2
<b><i>Maintenance</i></b>	<b><i>6</i></b>
Recalibration	6-1
Batteries	6-2
<b><i>Technical Theory of Operation</i></b>	<b><i>7</i></b>
Input	7-1
Amplifier	7-1
Discriminator	7-1
Scale Ranging	7-1
Digital Analog Converter	7-1

<b>Audio</b>	<b>7-2</b>
<b>Meter Drive</b>	<b>7-2</b>
<b>Meter Compensation</b>	<b>7-2</b>
<b>Fast/Slow Time Constant</b>	<b>7-2</b>
<b>Low Voltage Supply</b>	<b>7-2</b>
<b>Low Voltage Reference</b>	<b>7-2</b>
<b>High Voltage Supply</b>	<b>7-3</b>
<b>Alarm</b>	<b>7-3</b>
<b><i>Recycling</i></b>	<b><i>8</i></b>
<b><i>Radiation Basics</i></b>	<b><i>9</i></b>
<b><i>Troubleshooting</i></b>	<b><i>10</i></b>
<b>Troubleshooting Electronics which utilize a Scintillation Detector</b>	<b>10-1</b>
<b>Troubleshooting Scintillators</b>	<b>10-4</b>
<b><i>Parts List</i></b>	<b><i>11</i></b>
<b>Model 193 Survey Meter</b>	<b>11-1</b>
<b>Main Board, Drawing 464 X 253</b>	<b>11-1</b>
<b>Wiring Diagram, Drawing 464 × 560</b>	<b>11-4</b>
<b><i>Drawings and Diagrams</i></b>	<b><i>12</i></b>

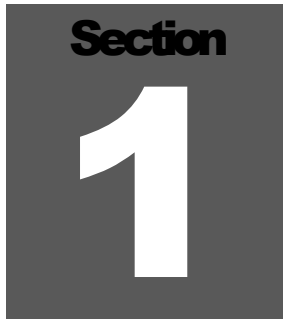
A dark gray square graphic with the word "Section" in white at the top and a large white number "1" in the center.

## Introduction

---

The Ludlum Model 193 Survey Meter is a portable gamma survey instrument with adjustable audio and visual alarms. The instrument is designed to be used with external scintillation detectors for optimum performance in locating and measuring low-level (near background) gamma radiation.

The Model 193 offers two types of alarms for both avid and inexperienced users: (1) a user-adjustable, meter-driven alarm for alarm indication above a particular set point, and (2) a deviation beep alarm, which gives indication to the rise of radiation above background levels.

The unit features range multipliers of  $\times 1$ ,  $\times 10$ ,  $\times 100$ , and  $\times 1000$ , which provide an overall range of 0-5000 microrentgens per hour ( $\mu\text{R}/\text{hr}$ ) when used in conjunction with a 0-5  $\mu\text{R}/\text{hr}$  meter dial (others are available). Other features include a two-position meter response time switch, adjustable detector operating voltage (HV), and an audio ON/OFF switch.

The instrument is capable of using either standard "D" cell flashlight batteries or nickel-cadmium rechargeable batteries. However, the Model 193 does not include circuitry for recharging the batteries. The two "D" cell batteries are located in an isolated compartment, easily accessible from the front panel.

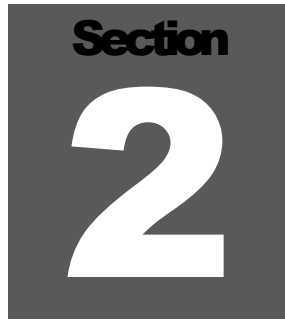
A dark gray square with the word "Section" in white at the top and a large white number "2" in the center.

## Getting Started

---

### Unpacking and Repacking

Remove the calibration certificate and place it in a secure location. Remove the instrument and accessories (batteries, cable, etc.) and ensure that all of the items listed on the packing list are in the carton. Check individual item serial numbers and ensure calibration certificates match. The Model 193 serial number is located on the front panel below the battery compartment. Most Ludlum Measurements, Inc. detectors have a label on the base or body of the detector for model and serial number identification.

#### Important!

If multiple shipments are received, ensure that the detectors and instruments are not interchanged. Each instrument is calibrated to specific detectors, and therefore not interchangeable.

To return an instrument for repair or calibration, provide sufficient packing material to prevent damage during shipment.

Every returned instrument must be accompanied by an **Instrument Return Form**, which can be downloaded from the Ludlum website at [www.ludlums.com](http://www.ludlums.com). Find the form by clicking the “Support” tab and selecting “Repair and Calibration” from the drop-down menu. Then choose the appropriate Repair and Calibration division where you will find a link to the form.

### Battery Installation

Ensure the Model 193 range selector switch is in the OFF position. Open the battery lid by pushing down and turning the quarter-turn thumbscrew counterclockwise, a quarter turn. Install two “D” size batteries in the compartment.

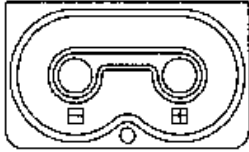

Note the (+) and (-) marks inside the battery door. Match the battery polarity to these marks. Close the battery box lid, push down and turn the quarter-turn thumb screw clockwise a quarter of a turn.

**Note:**

The center post of a flashlight battery is positive. The batteries are placed in the battery compartment in opposite directions.

## Connecting a Detector to the Instrument

**Caution!**

The detector operating voltage (HV) is supplied to the detector via the detector connector. A mild electric shock may occur if bodily contact is made with the center pin of the input connector. Switch the Model 193 range selector switch to the OFF position before connecting or disconnecting the cable.

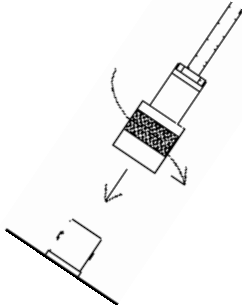

Connect one end of a detector cable to the detector by firmly pushing the connectors together while twisting clockwise a quarter of a turn. Repeat the process in the same manner with the other end of the cable and the instrument.

## Battery Test

The batteries should be checked each time the instrument is turned on. Move the range selector switch to the BAT position. Ensure that the meter needle deflects to the battery check portion on the meter scale. If the meter does not respond, check to see if the batteries have been correctly installed. Replace the batteries if necessary.

## Operational Check

Ensure that both toggle switches (AUD ON/OFF and F/S) are in the up (ON and F) position.

**Note:**

Operation of this instrument with the toggle switches in the down (OFF and S) position is not recommended for surveys. These positions should be used for specific measurements in a radiation field or hot spot.

Turn the range selector switch to the BAT position. The meter needle should fall within the BAT OK marks on the meter face. Replace the batteries if needed.

Background radiation levels are established by the instrument immediately following power-up, and for eight seconds thereafter. To signify that the instrument is not yet ready to survey, an audible beep will be heard and the ALARM lamp will flash (during the initial eight seconds after power-up). When the beeps are silenced, the instrument is ready for normal operation. The instrument then waits for an additional eight seconds before giving indication of detector fail condition. In the event of a detector failure, the instrument beeps rapidly and displays a meter reading of zero.

**Important!**

To ensure the highest sensitivity of beep deviation (increase in beep frequency) for small increases in background radiation, be sure to power-up the instrument (or press RESET) in an area of normal background radiation.

Turn the range selector switch to the  $\times 10$  position. If no source of radiation is nearby, any meter deflection should be due to background radiation. At Ludlum Measurements, a typical background reading is 6-12  $\mu\text{R/hr}$  (0.06-0.12  $\mu\text{Sv/h}$ ).

Expose the detector to a check source and verify that the instrument indicates within 20% of the check source reading obtained during the last calibration.

**Note:**

To aid in consistent check source readings between operational checks, orientate the source to the detector in identical fashion for each check.

Audible beeps should be heard with increasing frequency as the source is brought closer to the detector, and as the meter needle deflects upscale.

Ensure that the ALARM lamp and constant audible tone are activated when the check source is positioned to where the meter needle deflects above the alarm threshold.

The AUD ON/OFF switch will silence the audible clicks if in the OFF position. It is recommended that the AUD ON/OFF switch be kept in the OFF position when not needed in order to preserve battery life.

**Note:**

Operation of this instrument with the AUD ON/OFF switch in the down (OFF) position is not recommended for surveys. This position should be used for specific measurements in a radiation field or hot spot.

Increase the source activity for a meter reading of 10-100 uR/hr. While observing the meter fluctuations, select between the fast and slow response time (F/S) positions to observe variations in the display. The S position should respond approximately five times slower than the F position.

**Note:**

The slow response position is normally used when the instrument is displaying low numbers, which require a more stable meter movement. This position is not recommended for surveys. The fast response position is used at high rate levels.

Check the meter reset function by depressing the RESET pushbutton and by ensuring the meter needle drops to 0.

Proceed to use the instrument.

## Surveying for Radiation

### **Background and Manmade Radiation**

Naturally occurring background radiation is the main source of radiation exposure for most people. The amount of naturally occurring background radiation is dependent upon geographical location, environmental factors, and other conditions. When surveying for radiation, locating and measuring excess radiation above background is the main focus.

Radiation is also generated in a range of medical, commercial, and industrial activities. The most familiar, and in national terms, the largest of these sources of exposure is medical X-rays.

Background radiation contributes to about 88% of the annual dose rate the general public, while medical procedures contribute to most of the remaining 12%.

### **Radiation Limits**

The Code of Federal Regulations (CFR) limits the general public to radiation exposure of 100 mrem/year, with no more than 2 mrem of exposure in any one hour (ref. 10 CFR 20.1301). This limit will be discussed in detail in the following subsection.

### **Suggested Survey Technique**

Before beginning any survey, perform a battery test and operational check as previously described to ensure proper instrument operation.

To survey people or objects, hold the detector so that the front end is within 2.5-15.2 cm (1-6 in.) of the surface to be surveyed. Slowly move the detector over the surface while listening for *multiple* beeps.

#### **Note:**

Background radiation will occasionally cause the instrument to beep. However, *multiple* beeps indicate an increase in the level of radiation and the possible presence of radioactive material.

### **Range Selector and Actual Measurement**

When utilizing a 0-5  $\mu\text{R/hr}$  meter face, the following limits are associated with the range selector switch:

When in the  $\times 1$  position, the maximum measurable value is 5  $\mu\text{R/hr}$  (0.05  $\mu\text{Sv/h}$ ).

When in the  $\times 10$  position, the maximum measurable value is 50  $\mu\text{R/hr}$  (0.5  $\mu\text{Sv/h}$ ).

When in the  $\times 100$  position, the maximum measurable value is 500  $\mu\text{R/hr}$  (5  $\mu\text{Sv/h}$ ).

When in the  $\times 1000$  position, the maximum measurable value is 5000  $\mu\text{R/hr}$  (50  $\mu\text{Sv/h}$ ).

The value of 5000  $\mu\text{R/hr}$  is equal to 5  $\text{mR/hr}$  (0.05  $\text{mSv/h}$ ), and represents the largest exposure rate that can be measured by the instrument.

To determine the actual radiation measurement, multiply the meter reading by the set position of the range selector (multiplier) switch.

As previously stated, the CFR limits the general public to radiation exposure of 100  $\text{mrem/year}$ , with no more than 2  $\text{mrem}$  of exposure in any one hour. For gamma radiation only, this limit corresponds to about 100  $\text{mR/year}$  (1  $\text{mSv/year}$ ) with no more than 2  $\text{mR}$  (0.02  $\text{mSv}$ ) in any one hour.

**Example:**

Using this dose limit (no more than 2  $\text{mR}$  [0.02  $\text{mSv}$ ] in any one hour), if the Model 193 reads "5" while in the  $\times 1000$  range, a non-radiation worker would be allowed in the radiation field for no longer than 24 minutes.

**Note:**

The dose limits set by the CFR for the general public are considered by many to be very conservative, since a dose limit of up to five times this amount is allowed for occupational radiation workers with little to no known adverse health effects resulting from this increased limit.

**False Alarms**

Instrument false alarms often occur in the vicinity of those who have undergone some type of nuclear medical treatment. These treatments may include the ingestion or injection of radioactive substances, which may be measurable for several days after treatment.

Other materials are naturally radioactive, such as certain minerals dug from the ground, or trace amounts of radioactive material distributed uniformly throughout a load.

Meter readings above background and activated alarm indicators may be caused by either one of these situations. A careful survey should be performed to narrow the cause to one of these situations or a particular area of high radiation (hot spot).

**Important!**

In any case, take suitable precautions against any unnecessary exposure to radiation by minimizing exposure time, and by utilizing distance and shielding.

---

**Note:**

Additional material on the basics of radiation is provided in section 9 of this manual. If more information is desired, contact Ludlum Measurements, Inc.

---

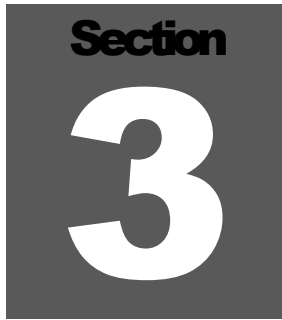
A dark gray square containing the word "Section" in a bold, white, sans-serif font at the top, and a large, white, bold number "3" centered below it.

## Specifications

---

**Linearity:** reading within 10% of true value. Depending upon the detector used, this instrument may respond to radiation from X-ray machines and pulsed radiation sources with erroneous readings due to the integration time of the instrument.

**High Voltage:** externally adjustable and variable from 200 to 1500 Vdc

**Battery Dependence:** instrument calibration change of less than 3% within the meter battery check limits

**Power:** two standard alkaline "D" cell batteries, secured in an isolated compartment

**Battery Life:** expected lifetime in excess of 600 hours with a fresh set of alkaline "D" cell batteries

**Audio Output:** built-in unimorph speaker and AUD ON/OFF switch provided on the front panel

**Audio:** audible click-per-deviation; beeps for every one-eighth second interval that is 2 sigma above background level; enabled or disabled by the AUD ON/OFF switch; corresponds to the ALARM lamp initiation

**Alarm:** The alarm is adjustable from 10% of full meter-scale to greater than full meter scale, with audio and visual indicators.

**Detector Failure:** indicated by a rapid audible beep and meter reading of zero. Instrument waits for eight seconds after initial power-up sequence before giving indication to a detector failure (no count) condition.

**Operating Range:** four linear range multipliers of  $\times 1000$ ,  $\times 100$ ,  $\times 10$ , and  $\times 1$ . Meter scale presentation of 0-5  $\mu\text{R}/\text{hr}$  provides an overall range of 0-5000  $\mu\text{R}/\text{hr}$  (other meter scales available).

**Meter:** 1 mA, 6.5 cm (2.5 in.) scale, pivot-and-jewel suspension

**Construction:** cast and drawn aluminum with beige powder-coat finish and silk-screened nomenclature

**Size:** 16.5 x 8.9 x 21.6 cm (6.5 x 3.5 x 8.5 in.) (H x W x L), including instrument handle

**Weight:** 1.6 kg (3.5 lb), including batteries

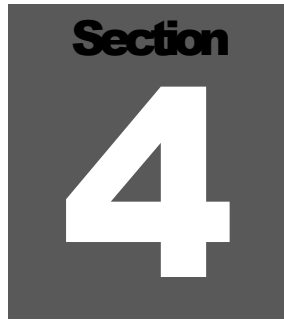

A dark gray square containing the word "Section" in a white sans-serif font at the top, and a large white number "4" in the center.

## Identification of Controls and Functions

---

**Range Selector Switch:** a six-position switch marked OFF, BAT,  $\times 1000$ ,  $\times 100$ ,  $\times 10$  and  $\times 1$ . When placed in the BAT position, battery charge status is indicated on the meter face. Moving the range selector switch to one of the range multiplier positions ( $\times 1000$ ,  $\times 100$ ,  $\times 10$  or  $\times 1$ ) provides the operator with an overall range of 0-5000  $\mu\text{R/hr}$  when used in conjunction with a 0-5  $\mu\text{R/hr}$  meter face. To determine the actual reading, multiply the scale reading by the range multiplier.

**AUD ON-OFF Toggle Switch:** When placed in the ON position, this switch activates the unimorph speaker, located on the left side of the instrument. The frequency of the clicks is relative to the rate of the incoming pulses. The higher the rate is, the higher the audio frequency. The audio should be turned OFF when not required, to reduce battery drain.

**F-S Toggle Switch:** provides meter response. Selecting the fast, "F," position of the toggle switch provides 90% of full-scale meter deflection in approximately four seconds. In the slow, "S," position, 90% of full-scale meter deflection takes approximately 22 seconds. In the "F" position there is fast response and large meter deviation. The "S" position should be used for slow response and damped meter deviation.

**ALARM Light:** When the meter pointer deflects above the alarm set point, this red lamp illuminates. This lamp flashes when radiation levels rise above background. In both cases the visual alarms will be accompanied by an audible alarm.

**RESET Pushbutton:** When depressed, this switch provides a rapid means of driving the meter needle to zero. Pressing RESET also causes an eight-second background update. During these eight seconds, the speaker will emit beeps and the ALARM light will flash every half-second.

**The following multi-turn potentiometers are located under the removable front panel calibration cover:**

**Alarm SET:** This multi-turn potentiometer is used to adjust the alarm threshold. The threshold is set by exposing the instrument and detector to the desired radiation field and by adjusting this potentiometer until the alarm point corresponds to the meter reading. The range is adjustable from 10-100% of full scale on each range multiple.

**DIS (Discriminator):** This multi-turn potentiometer is used to vary the detector pulse counting threshold (input sensitivity) from -10 to -30 mV. The discriminator is typically set at 30 mV and requires a Ludlum Model 500 Pulser (pulse generator) or equivalent to check or make adjustment to the input sensitivity.

**HV Adjustment:** This control provides a means to vary the detector operating voltage from 200 to 1500 volts. The high-voltage setting may be checked at the detector connection (internal) with an appropriate high impedance voltmeter.

**Range Calibration Adjustments:** These adjustment controls allow individual calibration for each range multiplier ( $\times 1000$ ,  $\times 100$ ,  $\times 10$ , and  $\times 1$ ).

Section  
**5**

## Safety Considerations

---

### Environmental Conditions for Normal Use

Indoor or outdoor use

No maximum altitude

Temperature range of -20 to 50 °C (-4 to 122 °F)

Maximum relative humidity of less than 95% (non-condensing)

Pollution Degree 3 (as defined by IEC 664) (Occurs when conductive pollution or dry nonconductive pollution becomes conductive due to condensation. This is typical of industrial or construction sites.)

### Warning Markings and Symbols

#### Caution!

The operator or responsible body is cautioned that the protection provided by the equipment may be impaired if the equipment is used in a manner not specified by Ludlum Measurements, Inc.

**The Model 193 Survey Meter is marked with the following symbols:**



**CAUTION, RISK OF ELECTRIC SHOCK** (per ISO 3864, No. B.3.6) – designates a terminal (connector) that allows connection to a voltage exceeding 1 kV. Contact with the subject connector while the instrument is on or shortly after turning off may result in electric shock. This symbol appears on the front panel.



**CAUTION** (per ISO 3864, No. B.3.1) – designates hazardous live voltage and risk of electric shock. During normal use, internal components are hazardous live. This instrument must be isolated or disconnected from the hazardous live voltage before accessing the internal components. This symbol appears on the front panel. **Note the following precautions:**

#### **Warning!**

The operator is strongly cautioned to take the following precautions to avoid contact with internal hazardous live parts that are accessible using a tool:

1. Turn the instrument power OFF and remove the batteries.
2. Allow the instrument to sit for one minute before accessing internal components.



The “**crossed-out wheellie bin**” symbol notifies the consumer that the product is not to be mixed with unsorted municipal waste when discarding; each material must be separated. The symbol is placed on the battery compartment lid. See section 8, “Recycling,” for further information.



The “CE” mark is used to identify this instrument as being acceptable for use within the European Union.

## **Cleaning and Maintenance Precautions**

The Model 193 may be cleaned externally with a damp cloth, using only water as the wetting agent. Do not immerse the instrument in any liquid. Observe the following precautions when cleaning or performing maintenance on the instrument:

1. Turn the instrument OFF and remove the batteries.
2. Allow the instrument to sit for one minute before cleaning the exterior or accessing any internal components for maintenance.

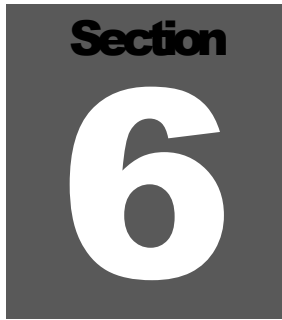
A dark gray square with the word "Section" in white at the top and a large white number "6" in the center.

## Maintenance

---

**I**nstrument maintenance consists of keeping the instrument clean and periodically checking the batteries and the calibration. The Model 193 instrument may be externally cleaned with a damp cloth (using only water as the wetting agent). Do not immerse the instrument in any liquid. Observe the following precautions when cleaning:

1. Turn the instrument OFF and remove the batteries.
2. Allow the instrument to sit for one minute before performing any external cleaning or accessing internal components for maintenance.

### **Recalibration**

Recalibration should be accomplished after any maintenance or adjustment of any kind has been performed on the instrument. Battery replacements are not considered maintenance and do not normally require instrument recalibration.

**Note:**

Ludlum Measurements, Inc. recommends recalibration at intervals no greater than one year. Check the appropriate regulations to determine required recalibration intervals.

Ludlum Measurements offers a full-service repair and calibration department. We not only repair and calibrate our own instruments, but most other manufacturers' instruments as well. Calibration procedures are available upon request for customers who choose to calibrate their own instruments.

**Batteries**

The batteries should be removed any time the instrument is placed into storage. Battery leakage may cause corrosion on the battery contacts, which must be scraped off and/or washed using a paste solution made from baking soda and water. Use a spanner wrench to unscrew the battery contact insulators, exposing the internal contacts and battery springs. Removal of the handle will facilitate access to these contacts.

**Note:**

Never store the instrument over 30 days without removing the batteries. Although this instrument will operate at very high ambient temperatures, battery seal failure may occur at temperatures as low as 37 °C (100 °F).

---

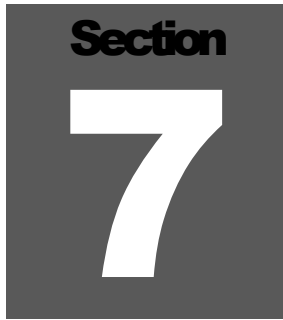
A dark gray square containing the word "Section" in a bold, white, sans-serif font at the top, and a large, white, sans-serif number "7" centered below it.

## Technical Theory of Operation

---

### Input

Detector pulses are coupled from the detector through C57 to emitter follower Q96. R83 and R89 provide bias. R137 protects Q96 from input shorts. R27 couples the detector to the high-voltage supply.

### Amplifier

Self-biased amplifier U1 provides gain in proportion to R63 divided by R70. Transistor pins 4, 5, and 6 of U1 provide amplification. Pins 10-15 are coupled as a constant current source to pin 6 of U1. The output self-biases to  $2 V_{be}$  (approximately 1.4 V) at pin 7 of U1. This provides just enough bias current through pin 6 to conduct all of the current from the constant current source. Positive pulses from pin 7 are coupled to the discriminator (U2) through R64 and C109.

### Discriminator

Comparator U2 provides discrimination. The discriminator is set by the voltage at pin 3 of U2. These pulses are coupled to pin 5 of U3 for meter drive and pin 12 of U3 for audio.

### Scale Ranging

Detector pulses from the discriminator are coupled to univibrator pin 5 of U3. For each scale, the pulse width of pin 6 of U3 is increased by a factor of 10, with the actual pulse width being controlled by the front-panel calibration controls and their related capacitors. This arrangement allows the same current to be delivered to C105 by one count on the  $\times 1$  range, and by 1000 counts on the X1000 range.

### Digital Analog Converter

Pin 12 and 15 of U4 are coupled as a current mirror. For each pulse of current through R72, an equal current is delivered to C105. This charge is

drained off by R74. The voltage across C105 is proportional to the incoming count rate.

## Audio

Discriminator pulses are coupled to univibrator pin 12 of U3. The front panel AUD ON-OFF selector controls the reset at pin 13 of U4. When ON, pulses from pin 10 of U3 turn on oscillator U5, which drives the can-mounted unimorph. Speaker tone is set by R84 and C112; with the duration by R86.

## Meter Drive

The meter is driven by the emitter to Q6, coupled as a voltage follower in conjunction with pin 1 of U6. For ratemeter drive, the meter is coupled to C105 at P1-15.

For battery test, the voltage follower is bypassed, and the meter movement is directly coupled to the battery through R150.

## Meter Compensation

When the unit is provided with a high-torque meter movement, with 1.2 V drive, a temperature compensation circuit is provided on the main circuit board; components R181, R189, and R190.

## Fast/Slow Time Constant

For slow time constant, C104 is switched from the output of the meter drive to parallel C105.

## Low Voltage Supply

Battery voltage is coupled to U7 and associated components (a switching regulator) to provide 5 V at pin 5 to power all logic circuits. Unregulated battery voltage is used to power the meter drive (Q6) and the high-voltage blocking oscillator (Q145).

## Low Voltage Reference

U101 provides a 1.22 V precision reference for the high-voltage supply. This unit also biases Q96.



## High Voltage Supply

High voltage is developed by blocking oscillator Q145-T165 and rectified by voltage multiplier CR166, 167, 169, and 175. Output voltage increases as current through Q44 increases, with maximum output voltage with Q44 saturated.

High voltage is coupled back through R47 to opamp pin 6 of U6. R147 completes the high-voltage circuit to ground. High-voltage output is set by the front-panel control HV, which sets bias of pin 5 of U6. During stable operation, the voltage at pin 6 of U6 will equal the voltage at pin 5 of U6. Pin 7 of U6 will cause conduction of Q44 to increase or decrease until the high voltage seeks a level of stability.

## Alarm

U2 is configured as a voltage comparator. The alarm SET potentiometer (wiper arm) is connected to pin 5 of U2. As the meter drive voltage, coupled to pin 6 of U2, increases above the alarm SET reference, pin 7 of U2 goes low. This causes Q200 to conduct, driving the drain of Q201 low and illuminating the ALARM lamp. Audio is generated from Q200 conduction through CR202 to RESET line of U5. R210 and Q213 provide the latching alarm circuitry. Pins 7, 8, and 9 of transistor U4 provide alarm reset by way of the front-panel RESET switch.

Section  
**8**

## Recycling

Ludlum Measurements, Inc. supports the recycling of the electronics products it produces for the purpose of protecting the environment and to comply with all regional, national, and international agencies that promote economically and environmentally sustainable recycling systems. To this end, Ludlum Measurements, Inc. strives to supply the consumer of its goods with information regarding reuse and recycling of the many different types of materials used in its products. With many different agencies – public and private – involved in this pursuit, it becomes evident that a myriad of methods can be used in the process of recycling. Therefore, Ludlum Measurements, Inc. does not suggest one particular method over another, but simply desires to inform its consumers of the range of recyclable materials present in its products, so that the user will have flexibility in following all local and federal laws.

The following types of recyclable materials are present in Ludlum Measurements, Inc. electronics products, and should be recycled separately. The list is not all-inclusive, nor does it suggest that all materials are present in each piece of equipment:

Batteries	Glass	Aluminum and Stainless Steel
Circuit Boards	Plastics	Liquid Crystal Display (LCD)

Ludlum Measurements, Inc. products that have been placed on the market after August 13, 2005, have been labeled with a symbol recognized internationally as the “crossed-out wheelee bin.” This notifies the consumer that the product is not to be mixed with unsorted municipal waste when discarding; each material must be separated. The symbol will be placed near the AC receptacle, except for portable equipment where it will be placed on the battery lid.

The symbol appears as such:

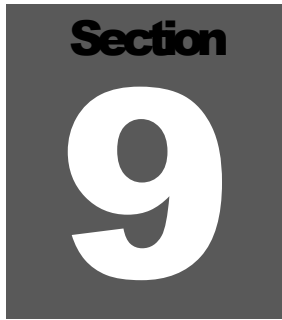

A dark gray square containing the word "Section" in a bold, white, sans-serif font at the top, and a large, white, sans-serif number "9" in the center below it.

## Radiation Basics

---

### Radiation and Life

*Adapted from Eric J. Hall's book, "Radiation and Life"*

Radiation is energy traveling through space. Sunshine is one of the most familiar forms of radiation. It delivers light, heat, and suntans. We control its effect on us with sunglasses, shade, air conditioners, hats, clothes, and sunscreen.

There would be no life on earth without lots of sunlight, but we have increasingly recognized that too much of it on our bodies is not a good thing. In fact, it may be dangerous, so we control our exposure to it.

Sunshine consists of radiation in a range of wavelengths from long-wave infrared to short-wavelength ultraviolet, which creates the hazard.

Beyond ultraviolet are higher energy kinds of radiation, which are used in medicine and that we all get in low doses from space, from the air, and from the earth. Collectively we can refer to these kinds of radiation as **ionizing radiation**. It can cause damage to matter, particularly living tissue. At high levels it is, therefore, dangerous, so it is necessary to control our exposure.

Background radiation is that which is naturally and inevitably present in our environment. Levels of this can vary greatly. People living in granite areas or on mineralized sands receive more terrestrial radiation than others, while people living or working at high altitudes receive more cosmic radiation. A lot of our natural exposure is due to radon, a gas which seeps from the earth's crust and is present in the air we breathe.

## The Unstable Atom

Radiation comes from atoms, the basic building blocks of matter.

Most atoms are stable; a carbon-12 atom, for example, remains a carbon-12 atom forever, and an oxygen-16 atom remains an oxygen-16 atom forever, but certain atoms eventually disintegrate into a totally new atom. These atoms are said to be “unstable” or radioactive. An unstable atom has excess internal energy, with the result that the nucleus can undergo a spontaneous change towards a more stable form. This is called radioactive decay.

When an atom of a radioisotope decays, it gives off some of its excess energy as radiation in the form of gamma rays or fast-moving, sub-atomic particles. One can describe the emissions as gamma, beta, and alpha radiation.

Apart from the normal measures of mass and volume, the amount of radioactive material is given in **curie** (Ci), a measure that enables us to compare the typical radioactivity of some natural and other materials.

### Radioactivity of some natural and other materials

1 adult human ( $2.7 \times 10^{-9}$ Ci/kg)	$1.89 \times 10^{-7}$ Ci
1 kg (2.2 lb) of coffee	$2.70 \times 10^{-8}$ Ci
1 kg (2.2 lb) of super phosphate fertilizer	$1.35 \times 10^{-7}$ Ci
The air in a 100 m <sup>2</sup> (1076 ft <sup>2</sup> ) Australian home (radon)	$8.12 \times 10^{-8}$ Ci
The air in many 100 m <sup>2</sup> (1076 ft <sup>2</sup> ) European homes (radon)	$8.12 \times 10^{-7}$ Ci
1 household smoke detector (with americium)	$8.12 \times 10^{-7}$ Ci
Radioisotope for medical diagnosis	$1.89 \times 10^3$ Ci
Radioisotope source for medical therapy	2702.7 Ci
1 kg (2.2 lb) of 50-year old vitrified high-level nuclear waste	270.27 Ci
1 luminous Exit sign (1970s)	27.027 Ci
1 kg (2.2 lb) of uranium	$675.68 \times 10^6$ Ci
1 kg (2.2 lb) of uranium ore (Canadian, 15%)	$675.68 \times 10^6$ Ci

1 kg (2.2 lb) of uranium ore (Australian, 0.3%)	13.51 X 10 <sup>6</sup> Ci
1 kg (2.2 lb) of low-level radioactive waste	27.03 X 10 <sup>6</sup> Ci
1 kg (2.2 lb) of coal ash	5.41 X 10 <sup>-8</sup> Ci
1 kg (2.2 lb) of granite	2.70 X 10 <sup>-8</sup> Ci

NB. Though the intrinsic radioactivity is the same, the radiation dose received by someone handling a kilogram of high grade uranium ore will be much greater than for the same exposure to a kilogram of separated uranium, since the ore contains a number of short-lived decay products (see section on Radioactive Decay).

## Radioactive Decay

Atoms in a radioactive substance decay in a random fashion but at a characteristic rate. The length of time this takes, the number of steps required, and the kinds of radiation released at each step are well known.

The half-life is the time taken for half of the atoms of a radioactive substance to decay. Half-lives can range from less than a millionth of a

second to millions of years, depending upon the element concerned. After one half-life, the level of radioactivity of a substance is halved, after two half-lives, it is reduced to one quarter, after three half-lives, to one-eighth and so on.

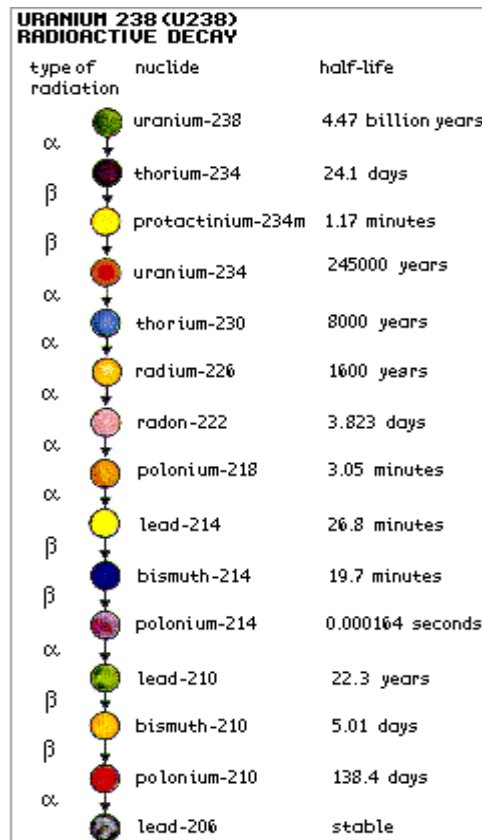

All uranium atoms are mildly radioactive. The following figure for uranium-238 shows the series of different radioisotopes it becomes as it decays, the type of radiation given off at each step and the half-life of each step on the way to stable, non-radioactive lead-206. The shorter-lived each kind of radioisotope, the more radiation it emits per unit mass. Much of the natural radioactivity in rocks and soil comes from this decay chain.

## Ionizing Radiation

Here we are concerned mainly with ionizing radiation from the atomic nucleus. It occurs in two forms – rays and particles – at the high frequency end of the energy spectrum.

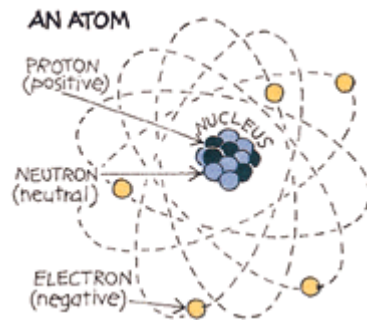

There are several types of ionizing radiation:

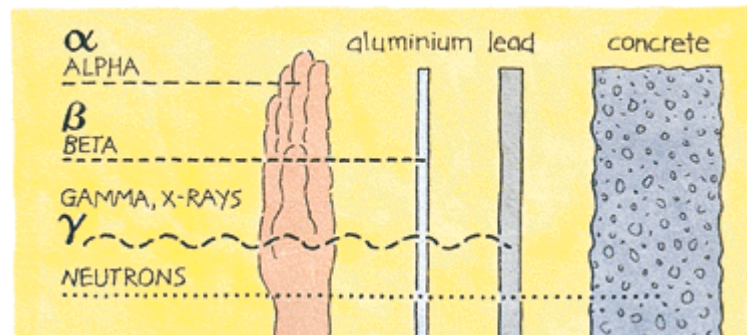

**X-rays and gamma rays**, like light, represent energy transmitted in a wave without the movement of material, just as heat and light from a fire or the sun travel through space. X-rays and gamma rays are virtually identical, except that X-rays are generally produced artificially rather than coming from the atomic nucleus. Unlike light, X-rays and gamma rays have great penetrating power and can pass through the human body. Thick barriers of concrete, lead, or water are used as protection from them.

**Alpha particles** consist of two protons and two neutrons, in the form of atomic nuclei. They thus have a positive electrical charge and are emitted from naturally occurring heavy elements such as uranium and radium, as well as from some man-made elements. Because of

their relatively large size, alpha particles collide readily with matter and lose their energy quickly. They, therefore, have little penetrating power and can be stopped by the first layer of skin or a sheet of paper.

However, if alpha sources are taken into the body, for example by breathing or swallowing radioactive dust, alpha particles can affect the body's cells. Inside the body, because they give up their energy over a relatively short distance, alpha particles can inflict more severe biological damage than other radiations.

**Beta particles** are fast-moving electrons ejected from the nuclei of atoms. These particles are much smaller than alpha particles and can penetrate up to 0.20 cm (5/64 of an inch) of water or human flesh. Beta particles are emitted from many radioactive elements. They can be stopped by a sheet of aluminum a few millimeters thick.

**Neutrons** are particles that are also very penetrating. On Earth they mostly come from the splitting, or fissioning, of certain atoms inside a nuclear reactor. Water and concrete are the most commonly used shields against neutron radiation from the core of the nuclear reactor.

**Note:**

It is important to understand that alpha, beta, gamma and X-radiation do not cause the body, or any object around the source, to become radioactive. However, most materials in their natural state (including body tissue) contain measurable amounts of radioactivity.

## Measuring Ionizing Radiation

### ***RAD and REM***

The human senses cannot detect radiation or discern whether a material is radioactive. However, a variety of instruments can detect and measure radiation reliably and accurately.

The amount of ionizing radiation, or 'dose', received by a person is measured in terms of the energy absorbed in the body tissue, and is expressed in **RAD**. One rad is 0.01 joules deposited per kilogram of mass.

Equal exposure to different types of radiation expressed as RAD, do not however, necessarily produce equal biological effects. One rad of alpha radiation, for example, will have a greater effect than one rad of beta radiation. When we talk about radiation effects, we, therefore, express the radiation as effective dose in a unit called the **REM** (Roentgen Equivalent Man).

Regardless of the type of radiation, one rem of radiation produces the same biological effect. (100 rem = 1 Sv)

Smaller quantities are expressed in mrem (one thousandth of a rem) or  $\mu$ rem (one millionth of a rem). We will use the most common unit, rem, here.

## What Are The Health Risks From Ionizing Radiation?

It has been known for many years that large doses of ionizing radiation, much larger than background levels, can cause a measurable increase in cancers and leukemias (cancer of the blood) after some years delay. It must also be assumed, because of experiments on plants and animals, that ionizing radiation can also cause genetic mutations that affect future generations, although there has been no evidence of radiation-induced mutation in humans. At very high levels, radiation can cause sickness and death within weeks of exposure. (See table on next page.)

But what are the chances of developing cancer from low doses of radiation? The prevailing assumption is that any dose of radiation, no matter how small, involves a possibility of risk to human health. However there is no scientific evidence of risk at doses below approximately 5 rem in a short period of time or about 10 rem over a period of one year.

Higher accumulated doses of radiation might produce a cancer that would only be observed several years (up to 20) after the radiation exposure. This delay makes it impossible to say with any certainty which of many possible agents were the cause of a particular cancer. In western countries, about a quarter of people die from cancers, with smoking, dietary factors, genetic factors and strong sunlight being among the main causes. Radiation is a weak carcinogen, but undue exposure could certainly increase health risks.



On the other hand, large doses of radiation directed specifically at a tumor are used in radiation therapy to kill cancerous cells, and thereby often save lives (usually in conjunction with chemotherapy or surgery). Much larger doses are used to kill harmful bacteria in food, and to sterilize bandages and other medical equipment. Radiation has become a valuable tool in our modern world.

## How Much Ionizing Radiation is Dangerous?

### **Radiation levels and their effects**

The following table gives an indication of the likely effects of a range of whole body radiation doses and dose rates to individuals:

**1000 rem** as a short-term and whole-body dose would cause immediate illness, such as nausea and decreased white blood cell count and subsequent death within a few weeks.

Between 200 and 1000 rem in a short-term dose would cause severe radiation sickness with increasing likelihood that this would be fatal.

**100 rem** in a short-term dose is about the threshold for causing immediate radiation sickness in a person of average physical attributes, but would be unlikely to cause death. Above 100 rem, severity of illness increases with dose.

If doses greater than 100 rem occur over a long period, they are less likely to have early health effects, but they create a definite risk that cancer will develop many years later.

Above about **10 rem**, the probability of cancer (rather than the severity of illness) increases with dose. The estimated risk of fatal cancer is 5 of every 100 persons exposed to a dose of 100 rem (ie. if the normal incidence of fatal cancer were 25%, this dose would increase it to 30%).

**5 rem** is, conservatively, the lowest dose at which there is any evidence of cancer being caused in adults. It is also the highest dose that is allowed by regulation in any one year of occupational exposure. Dose rates greater than 5 rem/yr arise from natural background levels in several parts of the world but do not cause any discernible harm to local populations.

**2 rem/yr** averaged over 5 years is the limit for radiological personnel such as employees in the nuclear industry, uranium or mineral sands miners, and hospital workers (who are all closely monitored).

**1 rem/yr** is the maximum actual dose rate received by any Australian uranium miner.

**300-500 mrem/yr** is the typical dose rate (above background) received by uranium miners in Australia and Canada.

**300 mrem/yr** (approximately) is the typical background radiation from natural sources in North America, including an average of almost 200 mrem/yr from radon in air.

**200 mrem/yr** (approximately) is the typical background radiation from natural sources, including an average of 70 mrem/yr from radon in air. This is close to the minimum dose received by all humans anywhere on Earth.

**30-60 mrem/yr** is a typical range of dose rates from artificial sources of radiation, mostly medical.

**5 mrem/yr**, a very small fraction of natural background radiation, is the design target for maximum radiation at the perimeter fence of a nuclear electricity generating station. In practice, the actual dose is less.

### ***What is the risk estimate?***

According to the Biological Effects of Ionizing Radiation committee V (BEIR V), the risk of cancer death is 0.08% per rem for doses received rapidly (acute) and might be two to four times (0.04% per rem) less than that for doses received over a long period of time (chronic). These risk estimates are an average for all ages, males and females, and all forms of cancer. There is a great deal of uncertainty associated with the estimate.

Risk from radiation exposure has been estimated by other scientific groups. The other estimates are not the exact same as the BEIR V estimates, due to differing methods of risk and assumptions used in the calculations, but all are close.

### ***Risk comparison***

The real question is: how much will radiation exposure increase my chances of cancer death over my lifetime.

To answer this, we need to make a few general statements of understanding. One is that in the US the current death rate from cancer is approximately 20 percent, so out of any group of 10,000 United States citizens, about 2000 of them will die of cancer. Second, that contracting cancer is a random process,

where given a set population, we can estimate that about 20 percent will die from cancer, but we cannot say *which* individuals will die. Finally, that a conservative estimate of risk from low doses of radiation is thought to be one in which the risk is linear with dose. That is, that the risk increases with a subsequent increase in dose. Most scientists believe that this is a conservative model of the risk.

So, now the risk estimates: If you were to take a large population, such as 10,000 people and expose them to one rem (to their whole body), you would expect approximately eight additional deaths ( $0.08\% \times 10,000 \times 1 \text{ rem}$ ). So, instead of the 2,000 people expected to die from cancer naturally, you would now have 2,008. This small increase in the expected number of deaths would not be seen in this group, due to natural fluctuations in the rate of cancer.

What needs to be remembered is that it is not known that 8 people will die, but that there is a risk of 8 additional deaths in a group of 10,000 people if they would all receive 1rem instantaneously.

If they would receive the 1 rem over a long period of time, such as a year, the risk would be less than half this (<4 expected fatal cancers).

Risks can be looked at in many ways. Here are a few ways to help visualize risk:

One way often used is to look at the number of "days lost" out of a population due to early death from separate causes, then dividing those days lost between the population to get an "Average Life expectancy lost" due to those causes. The following is a table of life expectancy lost for several causes:

<b>Health Risk</b>	<b>Est. life expectancy lost</b>
Smoking 20 cigarettes a day	6 years
Overweight (15%)	2 years
Alcohol (US Avg.)	1 year
All Accidents	207 days
All Natural Hazards	7 days
Occupational dose (300 mrem/yr)	15 days
Occupational dose (1 rem/yr)	51 days

You can also use the same approach to looking at risks on the job:

<b>Industry Type</b>	<b>Est. life expectancy lost</b>
All Industries	60 days
Agriculture	320 days
Construction	227 days
Mining and quarrying	167 days
Manufacturing	40 days
Occupational dose (300 mrem/yr)	15 days
Occupational dose (1 rem/yr)	51 days

These are estimates taken from the NRC Draft guide DG-8012 and were adapted from B.L. Cohen and I.S. Lee, "Catalogue of Risks Extended and Updates", *Health Physics*, Vol. 61, September 1991.

Another way of looking at risk, is to look at the Relative Risk of 1 in a million chances of dying of activities common to our society:

Smoking 1.4 cigarettes (lung cancer)
Eating 591 ml (40 tbsp) of peanut butter
Spending 2 days in New York City (air pollution)
Driving 64 km (40 m) in a car (accident)
Flying 4023 km (2500 m) in a jet (accident)
Canoeing for 6 minutes
Receiving 10 mrem of radiation (cancer)

Adapted from DOE Radiation Worker Training, based on work by B.L. Cohen, Sc.D.

## Background Radiation

Naturally occurring background radiation is the main source of exposure for most people. Levels typically range from about 150-350 mrem per year but can be more than 5rem/yr. The highest known level of background radiation affecting a substantial population is in Kerala and Madras States in India where some 140,000 people receive doses that average over 1.5 rem/year from gamma radiation, in addition to a similar dose from radon. Comparable levels occur in Brazil and Sudan, with average exposures up to about 4 rem/yr to many people.

Several places are known in Iran, India, and Europe where natural background radiation gives an annual dose of more than 5 rem and up to 26 rem (at Ramsar in Iran). Lifetime doses from natural radiation range

up to a couple thousand rem. However, there is no evidence of increased cancers or other health problems arising from these high natural levels.

## Man-made Radiation

Ionizing radiation is also generated in a range of medical, commercial, and industrial activities. The most familiar and, in national terms, the largest of these sources of exposure is medical X-rays.

Natural radiation contributes about 88% of the annual dose to the population and medical procedures contribute most of the remaining 12%. Natural and artificial radiations are not different in kind or effect.

## Protection from Radiation

Radiation is very easily detected. There is a range of simple, sensitive instruments capable of detecting minute amounts of radiation from natural and man-made sources. There are three ways in which people are protected from identified radiation sources:

**Limiting time:** For people who are exposed to radiation in addition to natural background radiation through their work, the dose is reduced and the risk of illness essentially eliminated by limiting exposure time. Proper job planning is essential in achieving lowest exposure time. Always plan for the unexpected to eliminate delays in the exposure area.

**Distance:** In the same way that heat from a fire is less the further away you are, so the intensity of radiation decreases with distance from its source. Distance is the easiest, fastest, and most practical way to limit exposure.

**Shielding:** Barriers of lead, concrete, or water give good protection from penetrating radiation such as gamma rays. Highly radioactive materials are, therefore, often stored or handled under water, or by remote control in rooms constructed of thick concrete or lined with lead.

## Standards and Regulation

Much of the evidence that has led to today's standards derives from the atomic bomb survivors in 1945, which were exposed to high doses incurred in a very short time. In setting occupational risk estimates, some allowance has been made for the body's ability to repair damage from small exposures, but for low-level radiation exposure, the degree of protection may be unduly conservative.

Most countries have their own systems of radiological protection, which are often based on the recommendations of the International Commission on Radiological Protection (ICRP). The “authority” of the ICRP comes from the scientific standing of its members and the merit of its recommendations.

## Who is in charge?

Ultimately, you are. All of the sources of radiation, other than natural, are regulated by laws passed by Congress. Like any other law, you have your right to voice your views and opinions about it. The regulations that control the use of radioactivity in our country are based upon recommendations of science organizations like the International Commission on Radiological Protection (ICRP), the National Council on Radiation Protection (NCRP), the International Atomic Energy Agency (IAEA), the United Nations (UN), and the Health Physics Society (HPS). Governing bodies like the Environmental Protection Agency (EPA), the Nuclear Regulatory Commission (NRC), the Department of Energy (DOE), and the Food and Drug Administration (FDA) review these recommendations and propose the regulations that industry and government must follow. These are then passed by Congress, if found to be acceptable, and published in the Code of Federal Regulations (CFRs).

**Note:**

The CFR limits the general public to radiation exposure of 100 mrem/year, with no more than 2 mrem of exposure in any one hour (ref. 10 CFR 20.1301).

**Section**  
**10****Troubleshooting**

---

Occasionally, you may encounter problems with your LMI instrument or detector that may be repaired or resolved in the field, saving turn-around time and expense in returning the instrument to us for repair. Toward that end, LMI electronics technicians offer the following tips for troubleshooting the most common problems. Where several steps are given, perform them in order until the problem is corrected. Keep in mind that with this instrument, the most common problems encountered are: (1) sticky meters and (2) battery contacts.

Note that the first troubleshooting tip is for determining whether the problem is with the electronics or with the detector. A Ludlum Model 500 Pulser is invaluable at this point, because of its ability to simultaneously check high voltage, input sensitivity or threshold, and the electronics for proper counting.

We hope these tips will prove to be helpful. As always, please call if you encounter difficulty in resolving a problem or if you have any questions.

**Troubleshooting Electronics which utilize a Scintillation Detector**

<u>SYMPTOM</u>	<u>POSSIBLE SOLUTION</u>
No power (or meter does not reach BAT TEST or BAT OK mark)	<ol style="list-style-type: none"><li>1. Check batteries and replace if weak.</li><li>2. Check polarity (see marks inside battery lid). Are the batteries installed backwards?</li></ol>

<b><u>SYMPTOM</u></b>	<b><u>POSSIBLE SOLUTION</u></b>
No power (or meter does not reach BAT TEST or BAT OK mark) (continued)	<ol style="list-style-type: none"> <li>3. Check battery contacts. Clean them with rough sandpaper or use an engraver to clean the tips.</li> <li>4. Check for loose or broken wires, especially between the main board and the calibration board.</li> </ol>
Nonlinear Readings	<ol style="list-style-type: none"> <li>1. Check the high voltage (HV) using a Ludlum Model 500 Pulser or equivalent. If a multimeter is used to check the HV, ensure that one with high impedance is used, as a standard multimeter could be damaged in this process.</li> <li>2. Check for noise in the detector cable by disconnecting the detector, placing the instrument on the lowest range setting, and wiggling the cable while observing the meter face for significant changes in readings.</li> <li>3. Check for “sticky” meter movement. Does the reading change when you tap the meter? Does the meter needle “stick” at any spot?</li> <li>4. Check the “meter zero.” Turn the power OFF. The meter should come to rest on “0.”</li> </ol>
Meter goes full-scale or “pegs out”	<ol style="list-style-type: none"> <li>1. Replace the detector cable to determine whether or not the cable has failed, causing excessive noise.</li> <li>2. Check the HV and, if possible, the input threshold for proper setting.</li> <li>3. Check for loose wires, especially between the main board and the calibration board.</li> </ol>



<u>SYMPTOM</u>	<u>POSSIBLE SOLUTION</u>
Meter goes full-scale or “Pegs Out” (continued)	4. Ensure that the instrument’s can is properly attached. When attached properly, the speaker will be located on the left side of the instrument. If the can is on backwards, interference between the speaker and the input preamplifier may cause noise.
No Response to Radiation	1. Substitute a “known good” detector and/or cable.  2. Has the correct operating voltage been set? Refer to the calibration certificate or detector instruction manual for correct operating voltage. If the instrument uses multiple detectors, confirm that the high voltage is matched to the current detector being used.
No Audio	1. Ensure that the AUD ON-OFF switch is in the ON position.  2. Remove the instrument housing and check the connection between the circuit board and the speaker. Plug in the 2-pin connector if necessary.
Rapid audible beep and a meter reading of zero	1. Has a detector been properly connected to the instrument? Ensure a proper connection. Change out the detector cable if necessary.  2. This symptom is often associated with a detector failure. Substitute a “known good” detector.

## Troubleshooting Scintillators

1. Alpha or alpha/beta scintillators are prone to light leaks. They can be tested for this problem in a dark room or with a bright light. If a light leak is determined, changing the metalized polyester window assembly will usually fix the problem.

**Note:**

When replacing the window, make sure to use a window made with the same thickness Mylar and the same number of layers as the original window.

2. Verify that the HV and input sensitivity are correct. Alpha and gamma scintillators typically operate from 10-35 mV. High voltage varies with the photomultiplier tubes (PMT) from as low as 600 Vdc, to as high as 1400 Vdc.
3. On a gamma scintillator, visually inspect the crystal for breakage or humidity leakage. Water inside the crystal will turn the crystal yellow and gradually degrade performance.
4. Check the PMT to see if the photocathode still exists. If the end of the PMT is clear (not brownish), this indicates a loss of vacuum which will render the PMT useless.

# Section 11

## Parts List

	<u>Reference</u>	<u>Description</u>	<u>Part Number</u>
<b>Model 193 Survey Meter</b>	UNIT	Completely Assembled Model 193 Survey Meter	48-2959
<b>Main Board, Drawing 464 x 570</b>	BOARD	Completely Assembled Circuit Board	5464-569
CRYSTAL	Y1	MICRO XTAL-4.0 MHz	01-5264
CAPACITORS	C1	10pF, 100V	04-5673
	C2	0.0033 $\mu$ F, 100V	04-5797
	C3	0.0022 $\mu$ F, 50V	04-5811
	C4	10pF, 100V	04-5673
	C5	0.01 $\mu$ F, 50V	04-5664
	C6	100pF, 3KV	04-5735
	C7	0.022 $\mu$ F, 50V	04-5667
	C8	1 $\mu$ F, 16V	04-5701
	C9	10 $\mu$ F, 25V	04-5655
	C10	100pF, 100V	04-5661
	C11	68 $\mu$ F, 10V	04-5654
	C12	10 $\mu$ F, 25V	04-5728
	C14	470pF, 100V	04-5668
	C15	220pF, 100V	04-5674
	C16	68 $\mu$ F, 10V	04-5654
	C17	47 $\mu$ F, 10V	04-5666
	C18-C27	0.01 $\mu$ F, 500V	04-5696
	C28	0.01 $\mu$ F, 2kV	04-5703
	C29	10 $\mu$ F, 25V	04-5655
	C30	1 $\mu$ F, 16V	04-5701
	C32	220pF, 100V	04-5674
	C33-C34	15pF, 100V	04-5721

	<u>Reference</u>	<u>Description</u>	<u>Part Number</u>	
TRANSISTORS	Q1	MMBT3904LT1G	05-5841	
	Q2	MMBT4403LT1G SMT*R	05-5842	
	Q3-Q5	2N7002LT1G	05-5840	
INTEGRATED CIRCUITS	U1-U3	MAX4542ESA	06-6453	
	U4-U5	CMXT3904TRLF	05-5888	
	U6	CMXT-3906TRLF	05-5890	
	U7	MAX4541ESA	06-6452	
	U8	MAX985EUK+T	06-6459	
	U9	CD74HC4538M96	06-6297	
	U10	LMC7111BIM5X	06-6410	
	U11	LT1304CS8-5#TRPBF	06-6434	
	U12	MIC1557YM5TR	06-6457	
	U13	LT1304CS8#TRPBF^SMT	06-6394	
	U14	MAX4543ESA-LFT SO-8	06-6596	
	U15	MAX985EUK+T	06-6459	
	U16	PIC12C509	06-6440	
	DIODES	CR1	CMPD2005SLF	07-6468
		CR2	CMSH1-40M	07-6411
		CR3-CR7	CMPD2005SLF	07-6468
CR8		CMPD2004C	07-6430	
CR9		CMSH1-40M	07-6411	
CR10		CMPD2004C	07-6430	
SWITCHES		SW1	D5G0206S-9802	08-6761
	SW2	TP11LTCQE PORTABLE RESET BUTTON	7464-186	
	SW3-SW4	A123S1CWCQ	08-6781	
RESISTORS	R1-R5	200K, 250mW, 1%	12-7992	
	R6	6.81K, 250mW, 1%	12-7857	
	R7	10K, 250mW, 1%	12-7839	
	R8	2.37K, 250mW, 1%	12-7861	
	R9-R11	10K, 250mW, 1%	12-7839	
	R12	200OHM, 250mW, 1%	12-7846	
	R13	10K, 250mW, 1%	12-7839	
	R14	4.75K, 250mW, 1%	12-7858	
	R15	200K, 250mW, 1%	12-7992	
	R16	10K, 250mW, 1%	12-7839	
	R17	1K, 250 mW, 1%	12-7832	
	R18	4.75K, 250mW, 1%	12-7858	
	R19	2K, 250 mW, 1%	12-7926	

	<u>Reference</u>	<u>Description</u>	<u>Part Number</u>
	R21	100K, 250mW, 1%	12-7834
	R22	1M, 250mW, 1%	12-7844
	R23	3.16K, 250mW, 1%	12-7903
	R24	14.7K, 250mW, 1%	12-7068
	R25	200K, 250mW, 1%	12-7992
	R26-R27	100K, 250mW, 1%	12-7834
	R29	1K, 250 mW, 1%	12-7832
	R31	475K, 250mW, 1%	12-7859
	R33-R34	250K, 64W254 Alarm Reset, DIS, X1, X100, X1000	09-6819
	R35	500K, 64W504, X10	09-6850
	R36	250K, 64W254 Alarm Reset, DIS, X1, X100, X1000	09-6819
	R37	100K, 250mW, 1%	12-7834
	R38	2.21M, 125mW, 1%	12-7002
	R39	500M, 3kV, 2%	12-7031
	R40	402K, 125mW, 1%	12-7888
	R41	200K, 250mW, 1%	12-7992
	R42	1.2M, 3296W, HV Adjust	09-6957
	R44	1K, 250 mW, 1%	12-7832
	R45	221OHM, 250mW 1%	12-7017
	R46	150 OHM, 250mW, 1%	12-7062
	R47	250K, 64W254 Alarm Reset, DIS, X1, X100, X1000	09-6819
	R48	200K, 250mW, 1%	12-7992
	R49	243K, 250mW, 1%	12-7112
	R50	21.5K, 250mW, 1%	12-7001
	R51	100K, 250mW, 1%	12-7834
	R52	33.2K, 250mW, 1%	12-7842
	R53	22.1K, 100mW, 1%	12-7094
	R54	250K, 64W254 Alarm Reset, DIS, X1, X100, X1000	09-6819
	R55	100K, 250mW, 1%	12-7834
CONNECTORS	P1	640456-4 MTA100x4	13-8088
	P2	640456-6 MTA100x6	13-8095
	P3	640456-2 MTA100x2	13-8073

	<u>Reference</u>	<u>Description</u>	<u>Part Number</u>
INDUCTOR	L1	22 $\mu$ H	21-9808
TRANSFORMER	T1	32377R	21-9925
MISCELLANEOUS	W1	TEFLON WHITE #22	21-8993
<b>Wiring Diagram, Drawing 464 x 560 CONNECTORS</b>	J1	MAIN BOARD 5464-569, MTA100 $\times$ 4 -26AWG	13-8170
	J2	MAIN BOARD 5464-569, MTA100 $\times$ 6-26AWG	13-8171
	J3	MAIN BOARD 5464-569, MTA100 $\times$ 2-26AWG	13-8178
	J4	UG706/U "C" COAX DONNECTOR	4478-011
	BATTERY	B1-B2	DURACELL "D"
MISCELLANEOUS	DS1	PT502-0UR-002F-W6 5V	21-99169
	DS2	TEC-3526-PU	21-9251
	M1	METER MOVEMENT 987010-001 (1mA)	15-8030

**Section**  
**12**

## **Drawings and Diagrams**

---

Model Board, Drawing 464 × 570 (4 sheets)

Model Board Component Layouts, Drawings 464 × 571A (2 sheets)

Wiring Diagram, Drawing 464 × 560

1

2

3

4

5

A

A

B

B

C

C

D

D

E

E

U\_464569R2P4  
464569R2P4.SchDoc



U\_464569R2P2  
464569R2P2.SchDoc

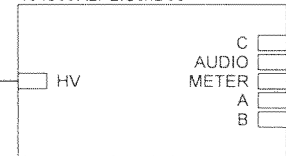

U\_464569R2P3  
464569R2P3.SchDoc



		<b>LUDLUM</b> MEASUREMENTS, INC.		PO Box 810 501 Oak Street Sweetwater, Texas 79556 U.S.A. 1-800-622-0828	
				Drawn: PAB	7/12/2016
Design: DL	7/12/2016	Model: 193		Board#: 5464-569	
Approve: <i>[Signature]</i>	<i>[Signature]</i>	Sheet: 1 of 4		Series	Sheet
Print Date: 9/30/2019 8:31:25 AM		Rev: 2		464	570
<small>W:\freedom\pcb\Projects\L\MIM 193 Series\193\5464-569\Rev2\464569R2P1.SchDoc</small>					

1

2

3

4

5





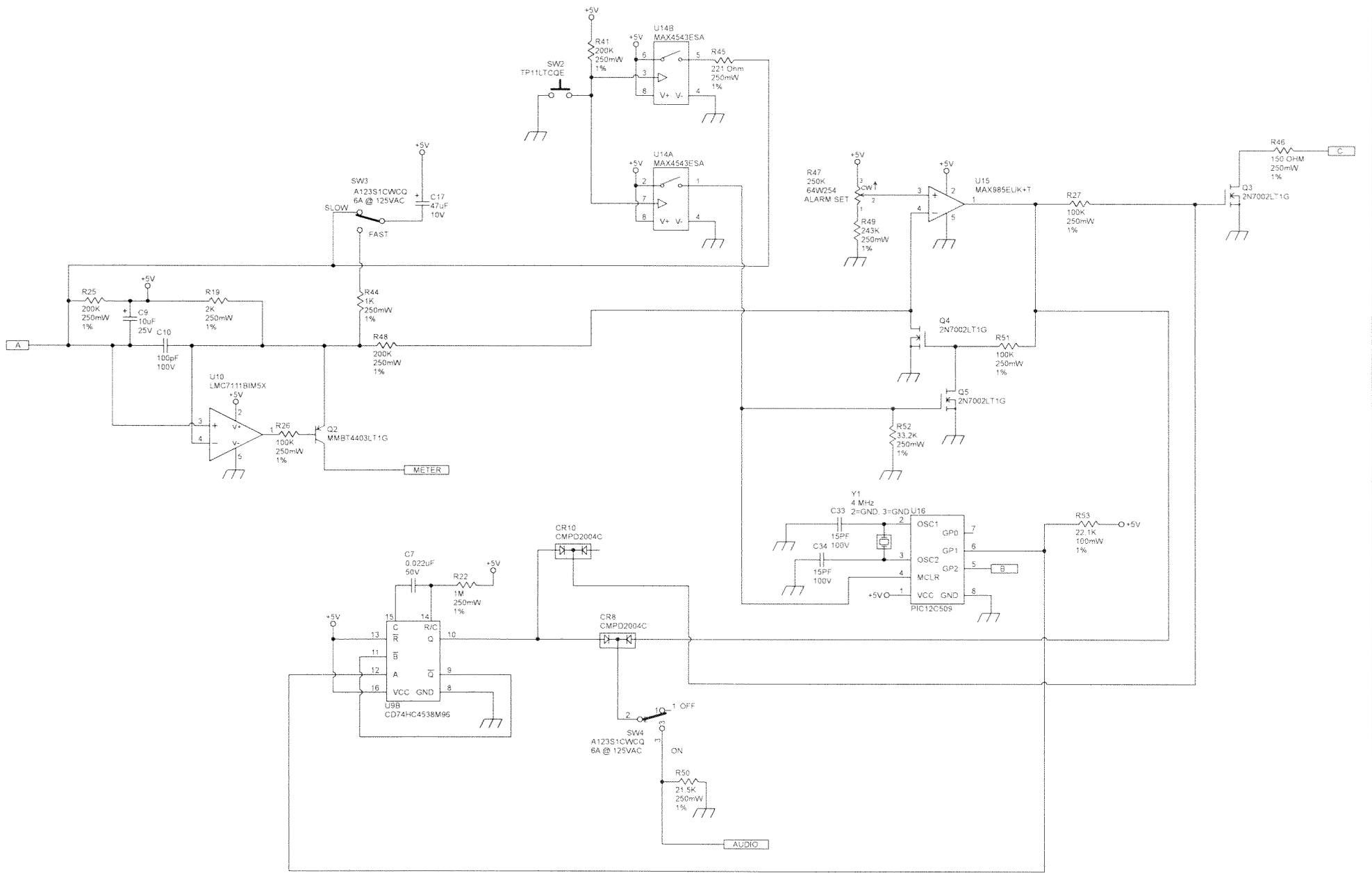

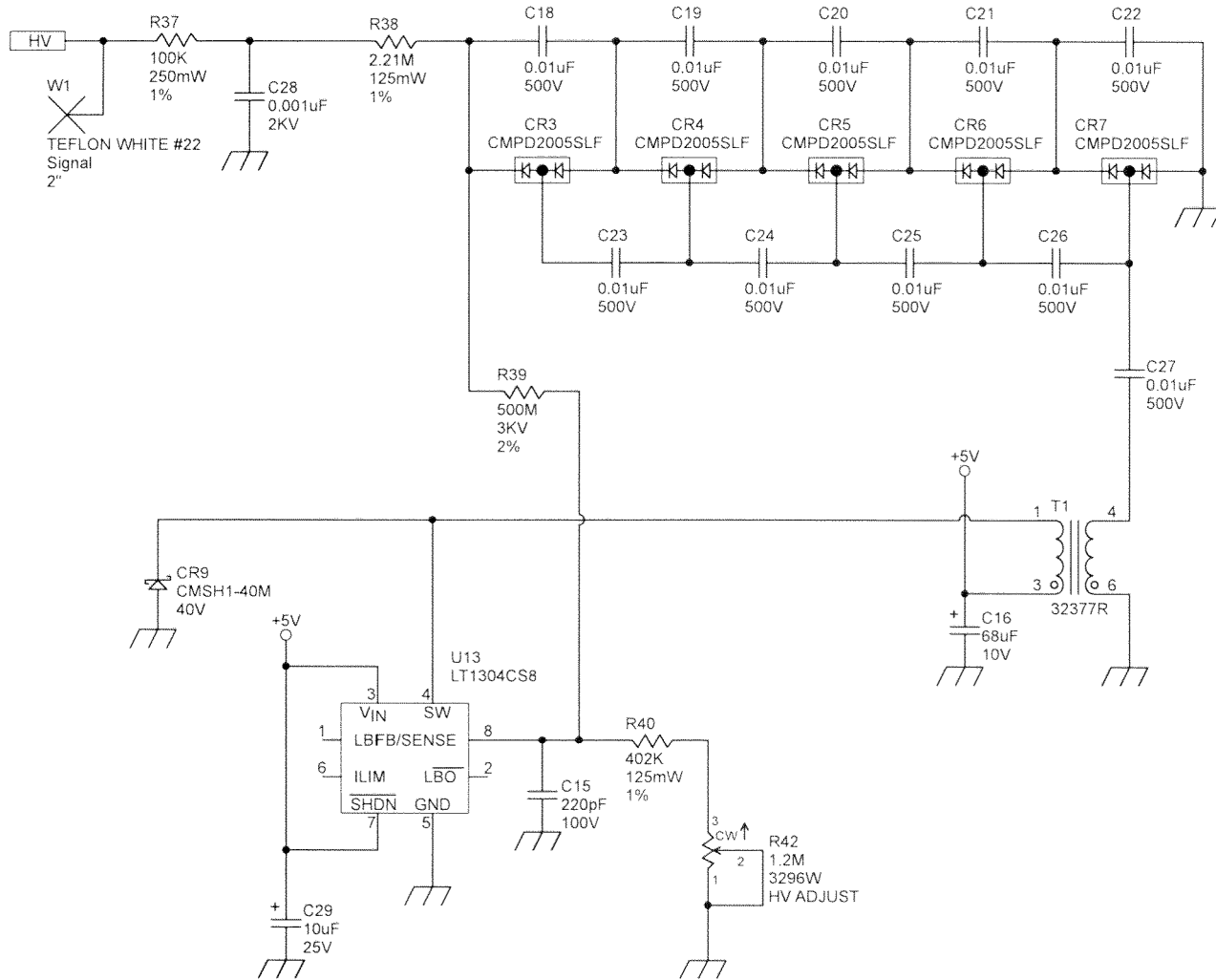

		P.O. Box 810 501 Oak Street Sweetwater, Texas 79556 U.S.A. 1-800-622-0828	
		Title: Main Board Model: 193 Board: 5464-569	Series: 464 Sheet: 570
Drawn: PAB Design: DL Approve:	7/12/2016 7/12/2016 8/31/2016 8:31:25 AM	Title: Main Board Model: 193 Board: 5464-569	Series: 464 Sheet: 570

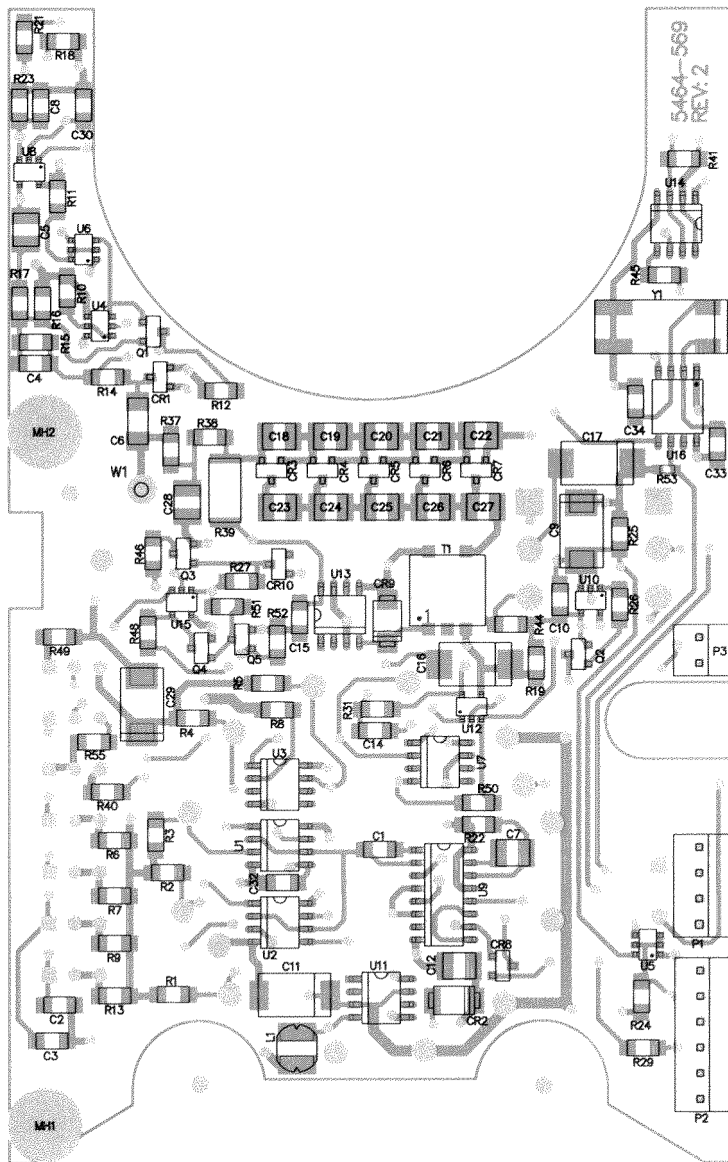

		PO Box 810 501 Oak Street Sweetwater, Texas 79556 U.S.A. 1-800-622-0828		
		Drawn: PAB 7/12/2016 Title: Main Board	Design: DL 7/12/2016 Model: 193	
Approve: <i>[Signature]</i>		Board#: 5464-569	Sheet: 4 of 4	Series
Print Date: 9/30/2019 8:31:26 AM		Rev: 2	464	Sheet 570
<small>W:\freedom\pcb\Projects\LMIM 193 Series\193\5464-569\Rev2\464569R2P4.SchDoc</small>				



 <b>LUDLUM</b> MEASUREMENTS, INC.		PO Box 810 501 Oak Street Sweetwater, TX 79556 U.S.A. 1-800-622-0828	
Title: Main Board			
Drawn: PAB	7/12/2016	Model: 193	
Design: DL	7/12/2016	Board#: 5464-569	
Approve: <i>PAB</i>	<i>[Signature]</i>	Rev: 2	
Print Date:		SCALE: 1.00	Series
9/30/2019	8:31:33 AM	Top Overlay	Sheet
		464	571 A
<small>\\freedom\pcb\Projects\LM\193 Series\193\5464-569\Rev2\464569R2 Assy.PcbDoc</small>			

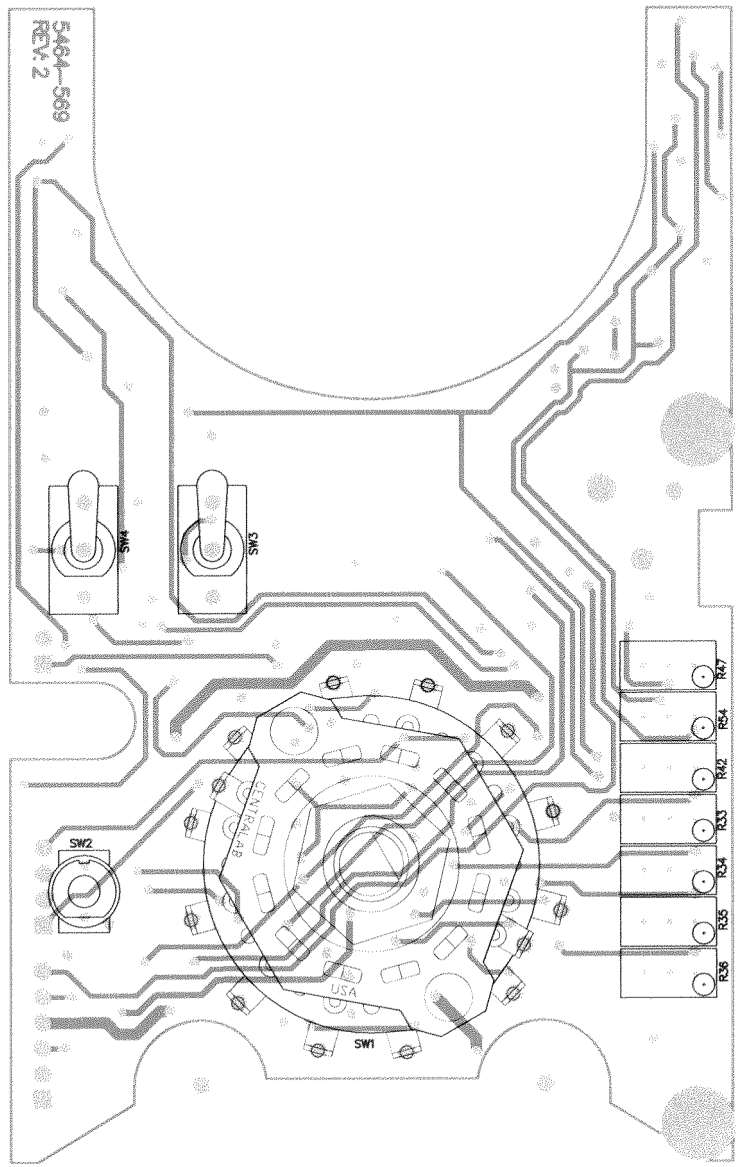

 <b>LUDLUM</b> MEASUREMENTS, INC.		PO Box 810 501 Oak Street Sweetwater, TX 79556 U.S.A. 1-800-622-0828	
Title: Main Board			
Drawn: PAB	7/12/2016	Model: 193	
Design: DL	7/12/2016	Board#: 5464-569	
Approve: <i>PAB</i>	<i>7/12/2016</i>	Rev: 2	
Print Date:		SCALE: 1.00	Series
9/30/2019	8:31:37 AM	Bottom Overlay	Sheet
		464	571 A
<small>\\freedom\pcb\Projects\LMIM 193 Series\193\5464-569\Rev2\464569R2 Assy.PcbDoc</small>			

WHITE TEFLON JUMPER

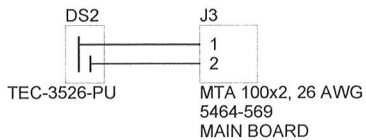
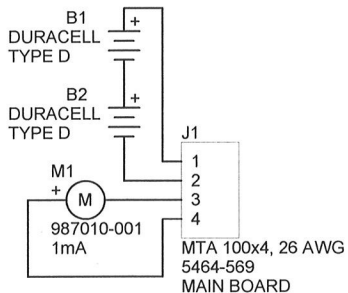
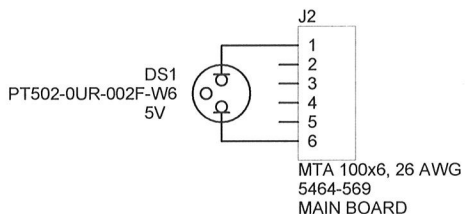
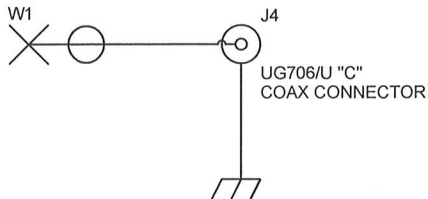

		PO Box 810 501 Oak Street Sweetwater, Texas 79556 U.S.A. 1-800-622-0828	
Drawn: ALC	08/12/2013	Title: WIRING DIAGRAM	
Design: RSS	08/12/2013	Model: 193	
Approve: <i>[Signature]</i>		Board#: 464-560	
Print Date: 8/19/2014 8:44:43 PM	Rev: 1	Sheet: 1 of 1	Series
W:\Projects\L\MIM 193 Series\193\464-560\Rev1\464560R1P1.SchDoc		464	560