

**LUDLUM MODEL 2221
PORTABLE SCALER RATEMETER**

Revised July 2020

**Serial Number 343649 and Succeeding
Serial Numbers**

**LUDLUM MODEL 2221
PORTABLE SCALER RATEMETER**

Revised July 2020

**Serial Number 343649 and Succeeding
Serial Numbers**



LUDLUM MEASUREMENTS, INC
501 OAK STREET, P.O. BOX 810
SWEETWATER, TEXAS 79556
325-235-5494, FAX: 325-235-4672

STATEMENT OF WARRANTY

Ludlum Measurements, Inc. warrants the products covered in this manual to be free of defects due to workmanship, material, and design for a period of twelve months from the date of delivery. The calibration of a product is warranted to be within its specified accuracy limits at the time of shipment. In the event of instrument failure, notify Ludlum Measurements to determine if repair, recalibration, or replacement is required.

This warranty excludes the replacement of photomultiplier tubes, G-M and proportional tubes, and scintillation crystals which are broken due to excessive physical abuse or used for purposes other than intended.

There are no warranties, express or implied, including without limitation any implied warranty of merchantability or fitness, which extend beyond the description of the face there of. If the product does not perform as warranted herein, purchaser's sole remedy shall be repair or replacement, at the option of Ludlum Measurements. In no event will Ludlum Measurements be liable for damages, lost revenue, lost wages, or any other incidental or consequential damages, arising from the purchase, use, or inability to use product.

RETURN OF GOODS TO MANUFACTURER

If equipment needs to be returned to Ludlum Measurements, Inc. for repair or calibration, please send to the address below. All shipments should include documentation containing return shipping address, customer name, telephone number, description of service requested, and all other necessary information. Your cooperation will expedite the return of your equipment.

**LUDLUM MEASUREMENTS, INC.
ATTN: REPAIR DEPARTMENT
501 OAK STREET
SWEETWATER, TX 79556**

**800-622-0828 325-235-5494
FAX 325-235-4672**

REV #	ALTERATIONS	DATE	BY
2	VALID	05/20/00	PW

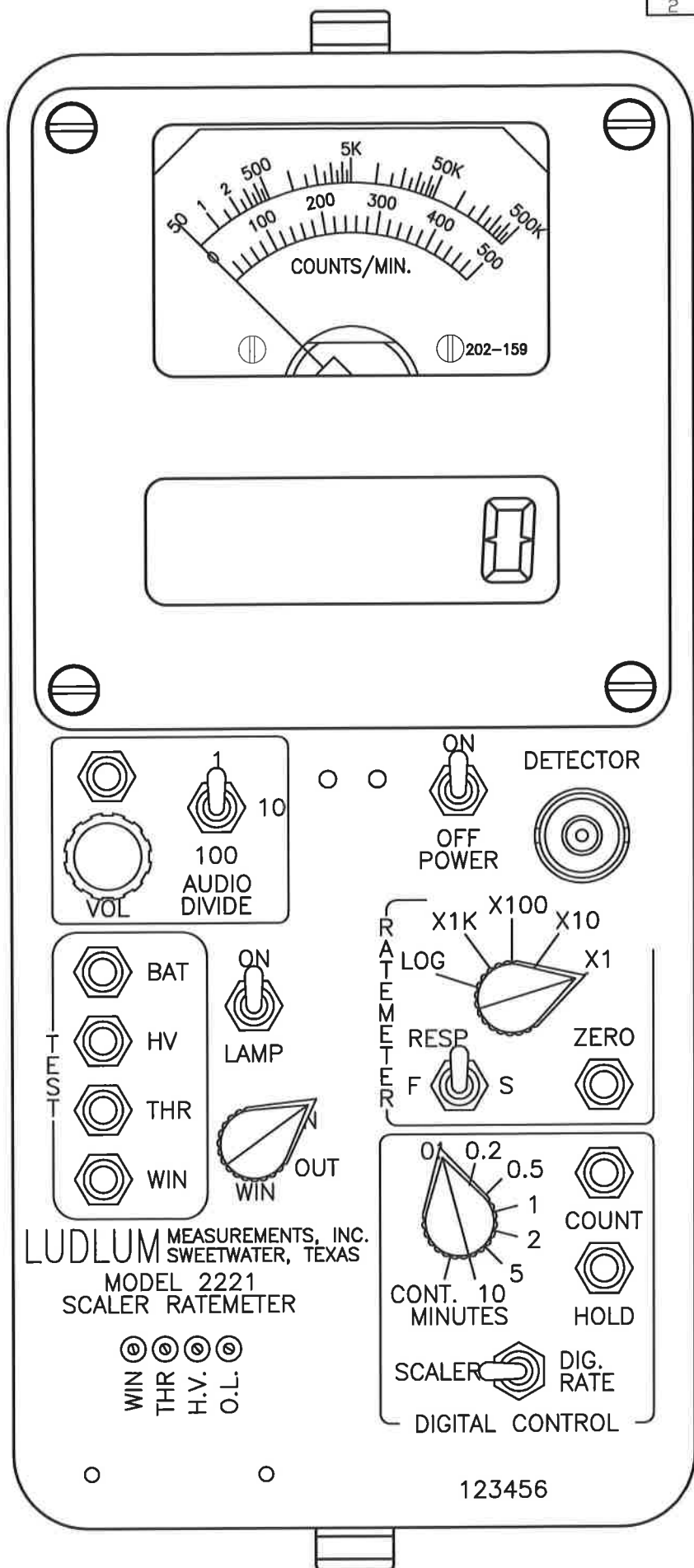

LUDLUM MEASUREMENTS, INC.
SWEETWATER, TEXAS
MODEL 2221
SCALER RATEMETER

Ⓞ Ⓞ Ⓞ Ⓞ
WIN THR H.V. O.L.

123456

DWN PW	DATE 05/20/00	CHECKED J6w 5-22-00	APPROVED P33 5-22-00
TITLE: MODEL 2221 PORTABLE SCALER			
LUDLUM MEASUREMENTS, INC. 501 DAK STREET SWEETWATER, TEXAS 79556		SERIES 261	SHEET 74

**Model 2221 Portable Scaler Ratemeter
July 2020**

TABLE OF CONTENTS

1. GENERAL.....	1
2. SPECIFICATIONS.....	1
3. DESCRIPTION OF CONTROLS AND FUNCTIONS.....	2
4. OPERATING PROCEDURES.....	4
4.1 Initial Preparation.....	4
4.2 Operating Point.....	4
4.3 Limitation of Controls.....	4
5. DETERMINING INSTRUMENT PLATEAU AND SELECTING OPERATING POINT.....	5
6. WINDOW OPERATION AND ENERGY CALIBRATION PROCEDURES.....	5
7. OVERLOAD DETECTION CALIBRATION.....	6
8. CALIBRATION.....	6
8.1 Ratemeter Calibration.....	6
8.2 TEST Pushbutton/Display Calibration.....	7
8.3 High Voltage Calibration.....	7
8.4 Threshold/Gain Calibration.....	7
9. OVERHAUL PROCEDURE.....	8
9.1 Amplifier/Power Supply Board.....	8
9.2 Processor Board Checkout.....	9
9.3 Functional/Chassis Checkout.....	11
10. PARTS LIST.....	14
Amplifier/Power Supply Board, Drawing 261 X 216.....	14
Processor Board, Drawing 261 X 91.....	15
Calibration Board, Drawing 261 X 59.....	16
LCD Display Board, Drawing 261 X 58.....	16
Backplane Board, Drawing 261 X 60.....	16
Chassis Wiring Diagram, Drawing 261 X 61.....	16
RS-232 Port Kit, Board Drawing 261 X 179.....	17
11. RS-232 PORT ADDITION.....	18
12. DRAWINGS AND DIAGRAMS.....	19

Model 2221 Portable Scaler Ratemeter

July 2020

1. GENERAL

The Ludlum Model 2221 Portable Scaler Ratemeter is a self-contained counting instrument designed for operation with scintillation, proportional, or GM detectors. Power is derived from four "D" cell batteries.

The unit is complete with a voltage-sensitive preamplifier, linear amplifier, electronic timer, detector high-voltage power supply, and detector overload detection circuitry.

A single channel analyzer is also featured in this unit for use in gamma spectrum analysis. The analyzer may be switched on or off, allowing gross or window counting.

The unit has a combination four-decade linear and log ratemeter and a six-digit LCD readout for the scaler and digital ratemeter. Potentiometers are supplied for threshold, window, and high-voltage controls.

2. SPECIFICATIONS

- **HIGH VOLTAGE:** 400 to 2400 volts with digital readout
- **CALIBRATION STABILITY:** less than 3% variance to battery endpoint
- **SENSITIVITY:** voltage sensitive and adjustable from 1.5 mV to 100 mV; typically factory calibrated to 10 mV = 100 on the THR display
- **INPUT IMPEDANCE:** 22k ohm
- **READOUT:** six-digit liquid crystal display, 1.3 cm (0.5 in.) characters with backlight selection
- **METER:** 6.4 cm (2.5 in.) scale, 1 mA, pivot and jewel suspension
- **SCALES/RANGE:** four-decade log ratemeter ranging from 50 to 500 kcpm; four decade linear ratemeter, 0-500 CPM meter dial with range multipliers of X1K, X100, X10, X1 producing an overall range of 0-500 kcpm
- **OPERATING TEMPERATURE:** -20 to 50 °C (-4 to 122 °F)
- **LINEARITY:** $\pm 10\%$ of the true value for the analog and digital ratemeter; $\pm 2\%$ of the true value for the digital Scaler, HV, THR, and WIN digital voltmeter readings; $\pm 4\%$ of the true value for the BAT voltmeter reading
- **RESPONSE:** two positions. Fast response = 4 ± 1 second. Slow response = 22 ± 2 second. All response times are measured from 10-90% of final reading.
- **CALIBRATION CONTROLS:** recessed screwdriver adjustments with calibration cover
- **AUDIO:** built-in unimorph speaker with click-per-event and switch selectable divide-by 1, 10, and 100
- **CONNECTOR:** Series "C"
- **BATTERY COMPLEMENT:** four each "D" cell batteries
- **BATTERY LIFE:** approximately 250 hours

Model 2221 Portable Scaler Ratemeter
July 2020

- **SIZE:** 22.9 x 10.9 x 25.4 cm (9 x 4.3 x 10 in.) (H x W x L), including handle
- **WEIGHT:** 2.5 kg (5.5 lb), including batteries
- **FINISH:** polyurethane enamel with silk-screened nomenclature

3. DESCRIPTION OF CONTROLS AND FUNCTIONS

- **POWER:** two-position ON-OFF switch
- **DETECTOR:** Series "C" connector for detector

Input Impedance: 22kΩ

Ballast Resistor: 1M

RATEMETER:

- **F-S RESP Switch:** two-position switch for selecting ratemeter response. F position 4 ±1 second; S position 22 ±2 seconds.
- **ZERO:** when pressed, resets the ratemeter
- **RANGE SELECTOR:** Five-position switch labeled LOG, X1K, X100, X10, X1 used to select the analog ratemeter range. The LOG position selects the upper meter scale to provide a four decade logarithmic reading from 50-500k CPM. The X1, X10, X100, and X1K range multipliers used with the lower 0-500 CPM meter scale, providing an overall measuring range from 0-500k CPM. Multiply the meter reading by the respective range position.

DIGITAL CONTROL:

- **COUNT Pushbutton:** When pressed, resets and starts the counter. While the counter is counting, two sets of colons are displayed.

- **HOLD Pushbutton:** When pressed, stops the counter and leaves the count in the display.

- **SCALER/DIG RATE Toggle Switch:** Two-position toggle switch for selecting scaler or digital ratemeter

SCALER Position: The display shows the counter contents.

DIG. RATE Position: The display shows the ratemeter count rate.

Note: The scaler and digital ratemeter are active even when not selected. This allows the user to start a timed count, switch to the digital ratemeter, and then switch back to scaler without having to restart the counter.

MINUTES Selector Switch: Eight-position switch used for selecting the count times for the scaler:

POSITION	COUNT TIME IN MINUTES
0.1	0.1
0.2	0.2
0.5	0.5
1	1
2	2
5	5
10	10
CONT	
COUNTER COUNTS UNTIL HOLD IS PRESSED	

Model 2221 Portable Scaler Ratemeter
July 2020

CALIBRATION CONTROLS:

- **WIN:** 20-turn potentiometer used to adjust window width when the window toggle switch, WIN, is in the "IN" position
- **THR:** 20-turn potentiometer used to adjust the threshold
- **HV:** 20-turn potentiometer used to adjust detector voltage
- **O.L.:** 20-turn potentiometer used to adjust detector overload current

TEST:

- **BAT Pushbutton Switch:** When pressed, displays the battery voltage in the digital display.
- **HV Pushbutton Switch:** When pressed, displays the detector high voltage in the digital display.
- **THR Pushbutton Switch:** When pressed, displays the threshold setting in the digital display.
- **WIN Pushbutton Switch:** When pressed, displays the window setting in the digital display.
- **LAMP Toggle Switch:** Two-position switch to turn on the display lights.
- **WIN Toggle Switch:** Two-position switch for switching the window IN or OUT.

IN position: The SCA (Single Channel Analyzer) is set up as a window counter. Detector pulses to be counted must be above the threshold but below the window.

OUT position: The SCA is set up as a gross counter. All detector pulses above the threshold are counted.

AUDIO:

- **VOL Control:** One-turn potentiometer used to adjust the volume of the speaker or headset.

- **AUDIO DIVIDE:**

1 Position: provides 1 click per event
10 Position: provides 1 click per 10 events
100 Position: provides 1 click per 100 events

- **1/8 inch HEAD PHONE JACK:** used for headset. When headset is plugged in, the unimorph speaker on the can is disabled.
- **LIQUID CRYSTAL DISPLAY:** 16.5 cm (6.5 in.) high digits, displaying counter contents or digital count rate

STATUS INDICATORS:

Counter Overflow: When in SCALER mode, the left digit alternates between the correct digit and an "H."

Detector Overload: The display flashes all dashes. ("-----").

Battery: When the battery voltage is 4.4 volts or less, all decimal points are turned on. This indicates that the batteries should be changed immediately.

Scaler Counting: The two colons are turned on when MINUTES selector switch is in CONT position.

4. OPERATING PROCEDURES

4.1 Initial Preparation

- Unscrew battery door latch.
- Install 4 "D" size batteries in the battery holder. The correct position of the batteries is indicated on the bottom of the battery door.
- Switch the POWER ON/OFF switch to the ON position. A random number will first be observed in the display, then 8.8:8.8:8.8. The third displayed number will be the program version. (At the time of this printing, program version is #261010.)
- Press COUNT pushbutton. The display should zero. Two sets of colons should appear on the display.
- Press HOLD pushbutton. The colons should disappear.
- Switch LAMP toggle switch to the ON position. LCD display backlighting and two lamps at the bottom of the analog meter should be illuminated.

NOTE: If the Lamp switch is left in the ON position for extended periods of time, battery life will decrease rapidly.

- Check TEST pushbutton functions for proper operation.

4.2 Operating Point

Instrument and detector operating point is established by setting the probe voltage (HV) and instrument sensitivity (THR). For a given detector system, efficiency, background and noise are fixed by the physical makeup of the detector and rarely vary from unit to unit. However, the selection of the operating point makes a

marked difference in the apparent contribution of these three sources of count.

In the singular case of the GM detector, a minimum operating voltage is required to establish the GM operating region. (At lower voltages, the detector operates as a very insensitive proportional counter.) This detector is not capable of energy discrimination (pulse-height discrimination). The threshold (THR) is typically adjusted to 550, with a THR reading of 100 = 10 mV input pulse for GM detectors.

For gain sensitive detectors (proportional or scintillation), the most straightforward method of selecting the operating point is to develop a graph, relating count rate to system gain. This relationship is commonly referred to as a plateau or instrument plateau curve. System gain may be changed by adjusting detector high voltage or THR control. The threshold is typically adjusted for 100 = 10 mV for scintillation detectors and 50 (5mV equivalent) on the THR readout for proportional detectors.

4.3 Limitation of Controls

HV Control provides a linear adjustment of the detector voltage supply. The range is approximately 400 to 2400 volts. Changing the detector voltage will cause the detector gain to change. It should be remembered that a linear change in voltage will cause an exponential change in detector gain. THR Control sets the basic pulse discrimination point of the scaler.

WIN Control is calibrated with the THR control so that the reading of the WIN control is equivalent to the reading of the THR control.

As an example, 100 on the THR is equal to 100 on the WIN.

Model 2221 Portable Scaler Ratemeter
July 2020

5. DETERMINING INSTRUMENT PLATEAU AND SELECTING OPERATING POINT

- Set WIN ON/OFF to OFF.
- Set MINUTES switch to 0.1 minutes.
- Set THR control at 100.
- With detector shielded from source, turn up high-voltage control and take a plot of HV versus background count rate until the detector maximum voltage rating is reached. (Maximum voltage on most scintillation detectors is 1500-1600 Vdc; maximum voltage on proportional detectors is reached at the continuous discharge point. Return HV control to minimum.
- Expose the detector to a source and again make a plot of voltage versus count.
- Plot both sets of data and select the operating point to correspond with maximum source count and minimum background count. Avoid areas of very fast count rate changes with small changes in detector voltage. The optimum operating point for low-background detectors is just above the inflection point (or break-over point or knee) of the plateau curve. If background count is irrelevant, shift operating point to the plateau center for greater stability.

6. WINDOW OPERATION AND ENERGY CALIBRATION PROCEDURES

The following procedure calibrates threshold directly in keV:

- Place RATEMETER multiplier switch to LOG position.
- Unscrew and remove CAL cover.
- Press HV pushbutton. The HV should read out on the display directly in volts. While depressing the HV pushbutton, turn HV potentiometer maximum counterclockwise. The HV should be less than 50 volts.
- Depress the THR pushbutton. Turn the THR potentiometer clockwise until 652 displays.
- With WIN IN/OUT switch IN, depress the WIN pushbutton. Turn the WIN potentiometer until 20 appears on the display.
- Switch WIN IN/OUT to OUT.
- Connect the probe and expose to a ^{137}Cs source (a source of approximately $10\mu\text{Ci}$ placed 3-4 inches away is recommended).
- Increase HV. (If HV potentiometer is at minimum, it will take approximately three turns before any change is indicated.) While increasing the HV, observe the log scale of the ratemeter. Increase HV until ratemeter indication occurs.
- Switch WIN IN/OUT switch to IN.
- Turn the HV control until maximum reading occurs on the log scale. Increase HV until reading starts to drop off, then decrease the HV for maximum reading.
- Turn RATEMETER selector switch to the X1K position.
- Press ZERO pushbutton and release. If meter does not read, switch to a lower range until a reading occurs.

Model 2221 Portable Scaler Ratemeter July 2020

- Carefully adjust HV potentiometer until maximum reading is achieved on the range scale. The instrument is now peaked for ^{137}Cs on both the LOG and Linear scales.

NOTE: When the THR control is adjusted, the effective window width remains constant. As an example, if the THR is set at 612, and the WIN at 100, a 662 keV peak $612 + (100 \text{ divided}$

by 2) will be centered in the window. Then the threshold point is equivalent to 612 keV with a 100 keV window and calibrated for 100 keV per turn. If the threshold is reduced to 250, the threshold is equivalent to 250 keV, but the window (100) is still equal to 100 keV. Proportionally, this represents a broader window.

7. OVERLOAD DETECTION CALIBRATION

- Detector count saturation is detected in this instrument and is indicated by the LCD display by flashing all dashes and the analog ratemeter deflecting full scale. The count saturation or "overload" point is calibrated by the O.L. front-panel control.
- Adjust the O.L. control to fully clockwise position.
- Connect detector and set HV for correct detector operating voltage.
- Expose detector to radiation field and while observing ratemeter, increase field intensity until a decrease in count rate is noticed. For alpha scintillators, the detector photomultiplier tube (PMT) should be exposed to a small light leak through the probe face to establish the detector saturation point.

- With the detector in the count saturation field, adjust the O.L. control counterclockwise until the overload alarm point is reached (flashing dashes in LCD display).
- Position detector in a lower field intensity just below the saturation point and confirm overload is defeated.

Example: Ludlum Model 44-9 GM pancake detector saturates at approximately 500 mR/hr (5 mSv/h).

- Full-scale instrument analog meter reading = 200 mR/hr (2 mSv/h). Set the Model 2221 to overload at 500 mR/hr (5 mSv/h) field, then position detector in a 300 mR/hr (3 mSv/h) field and confirm that overload alarm is defeated. The O.L. control will have to be "fine adjusted" to perform the above procedure.

8. CALIBRATION

Refer to schematic and component layout for the following calibration:

8.1 Ratemeter Calibration

- Connect frequency counter to pin 18 of U22 (80C51FA) on processor board, #5261-073.

Confirm crystal frequency is $6 \text{ MHz} \pm 0.1\%$ (6006-5994 kHz).

- Set THR control to 100 and Window IN/OUT switch to the OUT position.
- Connect Ludlum Model 500 Pulser or equivalent and adjust count rate for 40,000 CPM.

Model 2221 Portable Scaler Ratemeter

July 2020

- Switch Ratemeter Multiplier switch to the X100 position and the Response switch to "F."
- Adjust pulse amplitude above threshold until a steady count rate is observed on ratemeter.
- Adjust R40 Meter Cal (labeled MCAL) on Processor board, for 40,000 CPM on meter.
- Switch SCALER/DIG RATE switch to the SCALER position.
- Confirm counter time operation by taking 0.1 minute count. Colons should be observed during count cycle.
- Confirm HV will adjust from 400 to 2400-2500 volts. Ensure HV displayed reading tracks within 2% of HV output.

8.4 Threshold/Gain Calibration

8.2 TEST Pushbutton/Display Calibration

- Adjust THR control to fully clockwise position.
- Connect positive voltmeter lead to pin 7 of U3 (TLC27M7IP) on the amplifier/power supply board. Connect negative lead to ground near U3.
- Press the THR test pushbutton and adjust R171 Volt Cal (labeled "V"), so that the front-panel display reading corresponds to the voltmeter reading at pin 7 of U3.
- Set pulser pulse amplitude to 10 mV.
- With THR set at 100, fine adjust R174 gain control (on Power Supply board) until ratemeter reads 30,000 CPM with 40,000 CPM from pulser.
- Adjust THR control for readings of 200, 300, 400, and 500 to ensure the pulser input is 20, 30, 40, and 50 mV respectively. Use the 3/4 CPM input setting to discriminate turn on points as in procedure above.
- Adjust THR control back to 100.
- Switch Window IN/OUT switch to the IN position. Adjust WIN control for 100, 200, 300, 400, and 500 to confirm 20, 30, 40, and 50 mV window cut-off points.
- Set WIN back to 100 and OUT position.
- Check the rest of the front-panel functions for proper operation.

8.3 High Voltage Calibration

- Connect HV meter (1000 Megohm input impedance or greater) to the junction of R32 (4.7 Meg) and R33 (1 Meg) on the amplifier/power supply board.
- While pressing the HV Test pushbutton, adjust the HV front-panel control until the display reads 1500.
- Adjust R175 HV Cal on amplifier/power supply board for 1500 \pm 5 volts on external HV meter.

Model 2221 Portable Scaler Ratemeter
July 2020

9. OVERHAUL PROCEDURE

The checkout below can be performed with boards in instrument. An extender board (LMI part # 5261-098) is available if better access to board components is necessary:

9.1 Amplifier/Power Supply Board

- Connect low-voltage power supply, capable of supplying 4.0-5.0 Vdc to the Model 2221 and plug in amplifier/power supply board (component side to back of instrument).
- Adjust the WIN, THR, and O.L. front-panel controls to maximum clockwise position. Turn HV control to maximum counterclockwise position. Switch the lamp switch to the OFF position. Window IN/OUT switch to the OUT position.
- Adjust input voltage for approximately +4 Vdc and turn instrument to the ON position. Battery current should be approximately 30 mA or less.
- Confirm pin 8 of U7 (CA3290A) is equal to or greater than +6.4 Vdc.
- Increase supply voltage to approximately +5 Vdc and pin 8 of U7 should increase to +9 ±1 Vdc.
- Check for +5 ±0.15 Vdc at pin 8 of any of the TLC27M7IP circuits (such as U3 or U4).
- Check for -6.5 ± 0.5 Vdc at pin 4 of any of the same TLC27M7IP circuits.
- Connect subminax wire from detector input to amplifier/power supply board.
- Connect HV meter to detector input and adjust front-panel HV control to fully clockwise position.
- Adjust the HV front panel control to the fully clockwise position. Then adjust R175 HV CAL for approximately 2400-2450 Vdc. Decrease front-panel HV control to the fully counterclockwise position and confirm that HV output is 50 volts or less. Then set HV for approximately 1000 Vdc.
- Connect voltmeter to pin 1 of U3 (TLC27M7IP).
- With HV output set at approximately 1000 volts, adjust R176 Current Cal (labeled "O") for approximately 0.1 Vdc at pin 1 of U3.
- Connect Overrange Simulator (needs to have a 1000 meg resistor) to detector input and confirm pin 1 of U3 increases to approximately 0.15 ±0.01 Vdc.
- Connect voltmeter to pin 1 of U2 (LM358) and with the over-range simulator connected, adjust O.L. control on the front panel counterclockwise until the voltmeter reads approximately +0.5 Vdc. Disconnect simulator and confirm pin 1 of U2 goes above +3 volts.
- Turn O.L. control to its maximum clockwise position.
- Connect positive voltmeter lead to pin 7 of U3 (TLC27M7IP) and connect negative lead to ground close to U3.
- Press the WIN test pushbutton and confirm pin 7 of U3 is approximately 2.7 to 3.8 volts.
- Press THR test and confirm pin 7 is 1.23 ±0.02 Vdc.
- Press BAT test pushbutton and confirm pin 7 is approximately 0.5 with supply voltage at +5 Vdc.

Model 2221 Portable Scaler Ratemeter July 2020

- With the HV still set at 1000 Vdc, pin 7 of U3 should be approximately 1 ± 0.1 Vdc while pressing the HV test pushbutton.
- Connect oscilloscope to pin 3 of U5 (LM331) and adjust R171 Volt Cal (labeled "V") for approximately 2 kHz (0.5 millisecond period) with the HV pushbutton pressed.
- Connect voltmeter to pin 7 of U3, and while pressing the THR test pushbutton, adjust THR control for approximately +0.1 Vdc.
- Switch the Window IN/OUT switch to the IN position. While pressing the WIN test pushbutton, adjust the WIN control for approximately +0.1 Vdc at pin 7 of U3 also. Then switch the Window to the OUT position.
- Connect oscilloscope to pin 2 of U8 (CA3096).
- Connect pulser and set pulse amplitude for approximately 10 millivolts. Set CPM to 40,000.
- Adjust R174 Gain (labeled "G") to maximum clockwise position and confirm positive pulses at pin 2 of U8 are approximately 1 ± 0.1 volt in amplitude.
- Connect oscilloscope to pin 10 of U105 (CD4098).
- Adjust R174 Gain until pulses just start to appear at pin 10 of U105. Then adjust pulser amplitude until pulses are clearly visible.
- Adjust R173 T Pulse (labeled "T") for a 2.5 microsecond positive pulse width at pin 10 of U105.
- Connect oscilloscope to pin 7 of U105 and adjust R172 Width (labeled "W") for a 3 microsecond negative pulse width.
- Switch the Window IN/OUT switch to the IN position and verify that the pulses are present at pin 7 of U105 from 10 to 20 mV input pulse amplitude and off approximately above 20 mV.
- Switch Window IN/OUT switch to the OUT position and verify the pulses appear above the window limit as in the above step.
- Battery current should be less than 30 mA with +5 Vdc supply input.

9.2 Processor Board Checkout

- The procedure below is to be used without the Amplifier/Power Supply board. If the Amplifier/Power Supply board is used, delete the steps containing the signal generator use. Use the pulser for the standard count rate inputs. Window, Threshold, HV, and Bat Test will display the control setting.
- Plug in amplifier/power supply simulator board and connect signal generator to jumper wires (black= probe ground).
- Plug in processor board with component side toward back of instrument. Connect display ribbon cable.
- Set signal generator to square wave function.

Range = 10k and all other switches to the OUT position.
- Adjust the Frequency Symmetry, Amplitude and D.C. Offset controls to achieve a 5 volt negative pulse with a pulse width of approximately 50 microseconds and a period of approximately 1.2 milliseconds.
- With supply voltage set at $+5 \pm 0.15$ Vdc, turn instrument ON and observe display = 8.8:8.8:8.8 for approximately 2 seconds,

Model 2221 Portable Scaler Ratemeter July 2020

- then 261010 indicating the program number.
- Connect frequency counter to pin 18 of U22 (80C51FA) and confirm crystal frequency is 6 MHz $\pm 0.1\%$ (6006-5994 kHz).
 - Switch the Scaler/Dig. Rate Switch to the Dig. Rate position.
 - Counts should start accumulating every 2 seconds until approximately 50,000 CPM is observed. (The symmetry control can be fine adjusted until 50,000 CPM is achieved.) At this displayed count rate, the low BAT Test indication should be observed, indicated by 5 decimal points across the bottom of the display.
 - Press BAT Test and display should be 4.1 ± 0.2 .
 - Press HV and WINDOW = 410 ± 20 . Threshold pushbutton has no effect without amplifier/power supply plugged in.
 - Switch ratemeter response time to F.
 - Switch Ratemeter multiplier to X100.
 - Adjust R40 Meter Cal (labeled MCAL) until ratemeter matches displayed accumulated count (approximately 50,000 CPM).
 - Change the multiplier range on the signal generator to correspond to each decade on the rate multiplier to confirm range switch operation.
 - Connect voltmeter to recorder output and confirm R41 RCDR CAL (labeled RCAL) will adjust from 0 to approximately 3.7 Vdc, with full-scale CPM on display and ratemeter. Then set for 1 Vdc to equal full-scale meter deflection.
 - Connect oscilloscope to pin 9 of U10 (ICM7556) and decade sweep generator down to the 1k range.
 - Switch the Audio Divide switch between the 1, 10, and 100 positions to confirm audio frequency divides or multiplies by 10 between each position.
 - Connect headset or turn on unimorph and confirm volume control operation.
 - With full-scale meter deflection (500), check F/S response time (90% full scale) for 4.5 ± 0.5 seconds and 22 ± 2 seconds respectively.
 - Check Count, Hold, and Zero pushbutton functions.
 - Switch Scaler/Dig. Rate switch to the Scaler position and check the 0.1, 0.2, and 2 minute time multipliers for correct time operation.
 - With +5 volts supply input, battery current should be less than approximately 15 mA, with full-scale meter deflection.

Model 2221 Portable Scaler Ratemeter July 2020

9.3 Functional/Chassis Checkout

- This procedure requires a checked-out amplifier/power supply board and processor board.
- Connect one lead of an ohmmeter to chassis ground.
- Connect other lead of ohmmeter to the processor board cinch connector pins below to check count time switch operation. Boards are not plugged in yet.
1= open
0= shorted

COUNT TIME POSITION	PROCESSOR BOARD CINCH CONNECTOR		
	PIN 8	30	31
0.1	0	0	0
0.2	0	0	1
0.5	1	0	0
1	1	0	1
2	0	1	0
5	0	1	1
10	1	1	0
CONT	1	1	1

- Confirm display reads 8.8:8.8:8.8 for approximately 2 seconds, then 261010 indicating the program version.
- Connect positive voltmeter lead to pin 7 of U3 (TLC27M7IP) on the amplifier/power supply board. Connect negative lead to ground near U3.
- With the THR control full clockwise, press the THR test pushbutton and adjust R171 Volt Cal (labeled "V"), so that the front-panel display reading corresponds to the voltmeter reading at pin 7 of U3.
- Connect HV meter (2500 Megohm input impedance or greater) to the junction of R32 (4.7 Meg) and R33 (1 Meg) on power supply board.
- While pressing the HV Test pushbutton, adjust HV control until the display reads 1500. R176 Current Cal may have to be adjusted counterclockwise to defeat the Overrange function.
- Adjust R175 HV Cal on amplifier/power supply board for 1500 ±5 on external HV meter.
- Confirm HV will adjust from 400 to 2400 volts. Ensure HV displayed reading tracks within 2% of HV output.
- Adjust HV for approximately 1000 volts.
- Adjust R176 Current Cal (labeled "0") for approximately 0.1 volt at pin 1 of U3 (TLC27M7IP) on amplifier/power supply board.
- Connect over-range simulator (1000 megohm) to the detector input.
- Adjust the O.L. control counterclockwise until hyphens start flashing across the

- Connect external power supply and set input voltage for approximately +5 Vdc.
- Turn Lamp switch to the OFF position, THR, and O.L. controls to maximum clockwise position, and HV to maximum counterclockwise position.
- Plug in processor and amplifier/power supply boards and related cable connections.
- Turn instrument ON. Current draw should be less than 45 mA.

Model 2221 Portable Scaler Ratemeter July 2020

display every other count interval. Disconnect over-range simulator and confirm overrange function is defeated. Then adjust to fully clockwise position.

- Set THR control to 100 and Window IN/OUT switch to the OUT position.
- Connect pulser and adjust count rate for 40,000 CPM.
- Switch ratemeter multiplier switch to the X100 position and the response switch to "F."
- Adjust pulse amplitude above threshold until a steady count rate is observed on ratemeter.
- Adjust R40 Meter Cal (labeled MCAL) on processor board, for 400 CPM on meter.
- Adjust pulser for 10,000 CPM and check meter for $\pm 10\%$ linearity of reading. Adjust pulser and rate multiplier switch to confirm linear readings on all ranges.
- Switch SCALER/DIG. RATE switch to the SCALER position.
- Confirm count time switch operation by taking a 0.1 minute and 0.5 minute count. Colons should be observed during count cycle.
- Check HOLD and ZERO pushbutton functions.
- Switch SCALER/DIG. RATE switch to the DIG. RATE position and confirm update count display operation approximately every two seconds.
- Connect unimorph and headset to the audio outputs and confirm audio divide and volume control functions.

NOTE: Unimorph should shut off when headset is connected.

- With the THR control adjusted for 100, adjust R174 Gain (labeled G) for 1.5 millivolt input sensitivity. Ensure instrument functions at low input sensitivity without noise.
- Instrument may have to be placed in can to permit noise-free operation.
- Set pulser pulse amplitude to 10 mV.
- With THR still set at 100, fine adjust R174 gain control until ratemeter reads 30,000 CPM with 40,000 CPM from pulser.
- Adjust THR control for readings of 200, 300, 400, and 500 to ensure the pulser input is 20, 30, 40, and 50 mV respectively. Use the 3/4 CPM input setting to discriminate turn-on points as in procedure above.
- Adjust THR control back to 100.
- Switch Window IN/OUT switch to the IN position. Adjust WIN control for 100, 200, 300, 400, and 500 to confirm 20, 30, 40, and 50 mV window cut-off points.
- Set WIN back to 100 and OUT position for instrument shipment.
- Input a full-scale ratemeter count rate (500 CPM) and connect voltmeter to the recorder output. Adjust R41 (labeled RCAL) on processor board for 1 volt.
- Check F/S ratemeter response time for 4.5 ± 0.5 and 22 ± 2 seconds at 90% of full scale.
- Decrease input supply voltage until periods are observed at bottom of display. Press BAT Test pushbutton and confirm low BAT Test is 4.4 ± 0.1 Vdc. Adjust supply voltage back to 5 volts and confirm BAT test and actual supply input is 5 ± 0.05 Vdc.

Model 2221 Portable Scaler Ratemeter
July 2020

- Switch SCALER/DIG. RATE switch to the SCALER position, Count Time multiplier to CONT., then press count pushbutton and start with low enough count rate to observe each digital number count sequence from least significant digit to most significant digit (MSD). Decade pulser count rate to speed up digit segment display check.
- Increase count rate enough to overflow counter. An "H" should be observed in the MSD flashing every count interval.
- Turn Lamp switch to the ON position and confirm two lamps in the display and two lamps below the meter are illuminated.
- Current draw with lamps on should be 210 ± 20 mA.
- Turn lamp OFF, and current should be approximately 40 ± 5 mA.

**Model 2221 Portable Scaler Ratemeter
July 2020**

10. PARTS LIST

Ref. No.	Description	Part No.	Ref. No.	Description	Part No.
Model 2221 Portable Scaler Ratemeter			TRANSISTORS		
UNIT	Completely Assembled Model 2221 Portable Scaler Ratemeter	48-2065	Q130	2N3904G	05-5755
			Q173	MPS-W51AG	05-5765
			Q175	MPS-W01	05-5578
Amplifier/Power Supply Board, Drawing 261 X 216			INTEGRATED CIRCUITS		
BOARD	Assembled Board	5261-216	U1-U2	CMXT3904TRLF	05-5888
			U3	CMXT3906TRLF	05-5890
			U4-U6	CMXT3904TRLF	05-5888
			U146	CMXT3906TRLF	05-5890
			U153	TLC27M7IPE4	06-6248
			U171	CD4098BE	06-6066
			U187	TLC372IP	06-6265
			U191	LM358NG	06-6024
			U203	LM331N/NOPB	06-6156
			U211	CMXT3906TRLF	05-5890
			U220	TLC27M7IPE4	06-6248
			U230	LM2578	06-6223
			U235	TLC27M7IPE4	06-6248
			U248	CD4052BE	06-6141
			U256	CMXT3904TRLF	05-5888
CAPACITORS			DIODES		
C111	0.1μF, 100V, X7R	04-5521	CR121	GI250-2	07-6266
C116	0.0056μF, 3kV, C	04-5522	CR123	GI250-2	07-6266
C118	0.1μF, 100V, X7R	04-5521	CR125	GI250-2	07-6266
C122	0.0015μF, 3kV, NPO	04-5518	CR126	GI250-2	07-6266
C124	0.0015μF, 3kV, NPO	04-5518	CR133	IN4148	07-6272
C127-C128	0.0015μF, 3kV, NPO	04-5518	CR141	GI250-2	07-6266
C136-C137	0.1μF, 100V, X7R	04-5521	CR174	IN4148	07-6272
C142	100pF, 3kV, C	04-5532	CR176	1N4148	07-6272
C143	100pF, 100V, COG	04-5527	CR182	1N4148	07-6272
C154	0.1μF, 100V, X7R	04-5521	CR183	1N4148	07-6272
C155	100μF, 10V, DT	04-5576	CR192	1N4148	07-6272
C156	0.1μF, 100V, X7R	04-5521	CR213	1N5819	07-6306
C159	47pf, 100V, C	04-5533	CR228	1N5819	07-6306
C161	47pf, 100V, C	04-5533	CR236	1N4148	07-6272
C162	4.7μF, 10V, DT	04-5578	CR243	1N5819	07-6306
C169	100pF, 100V, COG	04-5527	CR244	1N5252	07-6265
C172	100μF, 10V, DT	04-5576	CR246	IN4148	07-6272
C179	0.0022μF, 100V, P	04-5580			
C180	1μF, 35V, DT	04-5575			
C188	0.01μF, 100V, X7S	04-5523			
C190	0.1μF, 100V, X7R	04-5521			
C199	0.1μF, 100V, X7R	04-5521			
C200	1μF, 35V, DT	04-5575			
C205	0.1μF, 100V, X7R	04-5521			
C212	100pF, 3kV, C	04-5532			
C221	4.7μF, 10V, DT	04-5578			
C222	100μF, 10V, DT	04-5576			
C224	0.1μF, 100V, X7R	04-5521			
C232-C233	0.0056μF, 3kV, C	04-5522			
C239	10pF, 100V, C	04-5573			
C240	0.001μF, 100V, X7R	04-5519			
C241	2.2μF, 25V, DT	04-5559			
C245	10μF, 20V, DT	04-5592			
C250	4.7μF, 10V, DT	04-5578			
			RESISTORS		
			R110	4.7M	10-7030
			R112	1k	12-7750
			R113	10k	12-7748
			R114	220 OHM	12-7753
			R115	200k	12-7752
			R117	4.7k	12-7755
			R119	100k	12-7747

**Model 2221 Portable Scaler Ratemeter
July 2020**

Ref. No.	Description	Part No.	Ref. No.	Description	Part No.
DIODE			CONNECTOR		
CR45	1N4148	07-6272	P6/1-7	640457-7 MTA100	13-8183
RESISTORS			LCD Display Board, Drawing 261 X 58		
R27	3.3k	10-7013	BOARD	Assembled Board	5261-074
R28	220k	10-7066	INTEGRATED CIRCUIT		
R29	130k	10-7067	U7	3918	07-6252
R30	470k	10-7026	RESISTORS		
R31	220k	10-7066	R4	22 OHM	10-7072
R32	2.2k	10-7012	R14	22 OHM	10-7072
R33	5.6k	10-7042	CONNECTORS		
R40	1M TRIMMER	09-6828	P4	7-146256-5 HEADER	13-8186
R41	1M TRIMMER	09-6828	P5	640456-2 MTA100	13-8073
RESISTOR NETWORKS			MISCELLANEOUS		
R34-R35	NETWORK-22k SIP 10 PIN	12-7566	DS10-DS13	BULB-#6833	22-9613
TRANSFORMER			Backplane Board, Drawing 261 X 60		
T37	Model 300-9	4275-074	BOARD	Assembled Backplane Board	5261-076
CRYSTAL			DIODE		
Y39	6.000 MHZ	01-5209	CR6	1N5819	07-6306
CONNECTOR			CONNECTORS		
P3/1-50	RIBBON-1-102159-0	13-7834	J1-J2	EZA22DRSN	13-8181
MISCELLANEOUS			P7	640456-7 MTA100	13-8115
2 EA.	RIBBON-102312-2 LATCH	13-7804	P8	1-640456-4 MTA100	13-8141
Calibration Board, Drawing 261 X 59			P9	640456-5 MTA100	13-8057
BOARD	Assembled Board	5261-075	P10	640456-2 MTA100	13-8073
VOLTAGE REFERENCES			P11	1-640456-4 MTA100	13-8141
U1	LM385Z-1.2	05-5808	Chassis Wiring Diagram, Drawing 261 X 61		
U2	LM385Z-1.2	05-5808	AUDIO		
U3	LM385Z-1.2	05-5808	DS1	UNIMORPH 60690	21-9251
RESISTORS			CONNECTORS		
R4	22k	12-7754	J1	CONN-640456-2 MTA100	13-8073
R10	22k	12-7754	J2	UG706/U SERIES C	4478-011
R11	100k TRIMMER	09-6813	J5	PHONE JACK TINI #42A	21-9333
R12	100k TRIMMER	09-6813			
R13	100k TRIMMER	09-6813			
R14	100k TRIMMER	09-6813			

**Model 2221 Portable Scaler Ratemeter
July 2020**

Ref. No.	Description	Part No.
J6-J7	(ON CAL HARNESS)	8261-088
J8	(ON MAIN HARNESS)	8261-087
J9	(ON BATTERY HARNESS)	8261-089
J10	NOT USED	
J11	(ON MAIN HARNESS)	8261-087

SWITCHES

S1-S7	30-1-PB GRAYHILL	08-6517
S8-S12	7101-SYZ-QE TOGGLE	08-6511
SW1	513381	08-6656
SW2	513381	08-6656
SW3	MTA-206PA	08-6657

BATTERY

B1-B4	1.5 VOLT "D" DURACELL	21-9313
-------	-----------------------	---------

RESISTORS

R1	10k NON-LOCKING	09-6753
----	-----------------	---------

MISCELLANEOUS

M1	Model 2221 METER ASSY.	4261-091
----	------------------------	----------

RS-232 Port Kit (optional) 4261-148

RS-232 Board, Drawing 261 X 179

BOARD	Assembled RS-232 Board	5261-179
-------	------------------------	----------

CAPACITORS

C1	4.7 μ F, 20V, SMT	04-5653
C2	10 μ F, 20V, SMT	04-5655
C3	4.7 μ F, 20V, SMT	04-5653
C4	10 μ F, 20V, SMT	04-5655
C5-C6	68 μ F, 10V, SMT	04-5654

INTEGRATED CIRCUITS

U001	IC-MAX220CSE, SMT	06-6329
------	-------------------	---------

**Model 2221 Portable Scaler Ratemeter
July 2020**

11. RS-232 Port Addition (LMI Part No. 4261-148)

The Model 2221 RS-232 port addition allows the Model 2221 data to be read as output to a computer or serial printer, by dumping either the ratemeter or scaler reading as desired. The desired reading is selected with a toggle switch located in the digital control section of the front panel, labeled with two positions: SCALER and DIG. RATE. The port addition kit (LMI Part No. 4261-148) includes the internal board and a cable that will connect directly to a 9-pin PC port.

The scaler reading dumps when the scaler has completed a count. The ratemeter is dumped every two seconds in one of three formats, depending on the firmware installed. The three available formats are 1 count per 2 seconds, 2 counts per 60 seconds (cpm), or 3 counts per second (cps). Data output is always in a six-digit format with a letter prefix, corresponding to the following:

Ratemeter: "R"

Scaler: According to the table below

Letter Prefix	Time of Count (min)	Time of Count (sec)
	Format 1 or 2	Format 3 (cps version)
A	0.1	1
B	0.2	2
C	0.5	5
D	1.0	10
E	2.0	30
F	5.0	60
G	10.0	120

A carriage return and then a line-feed character follows the sixth digit.

The communication protocol is 9600 baud, no parity, 1 stop bit, and 8 data bits. The RS-232 port is for output only with no handshaking available.

The Model 2221 will dump the data, no matter what, even if the attached computer or printer is not read. The cable provided is a coaxial cable, providing TXD and GND to a 9-pin D connector, ready to plug into a standard PC serial port.

Windows Hyper Terminal may be used to display and/or log the readings.

The Model 2221 processor board utilizes an EPROM with one of the following firmware numbers, depending on the desired rate:

Rate Dump as counts per 2 seconds – #261-06-N03.

Rate Dump as counts per 60 seconds – #261-07-N02.

Rate Dump as counts per second with meterface 202-930 – #261-02-N02.

261-06-N03 RS-232 output rate dump as counts per 2 seconds.

261-07-N02 RS-232 output rate dump as counts per 60 seconds.

261-02-N02 RS-232 output rate dump as counts per second (cps) with special meterface 202-930 (0-10 kcps).

261-02-N04 NEW RS-232 output every second, 0-10 kcps meterface 202-930, 1,2,5,10,30,60,120 sec scaler.

261-02-N07 NEW RS-232 output every second, original meterface, cpm RS-232 output.

**Model 2221 Portable Scaler Ratemeter
July 2020**

12. DRAWINGS AND DIAGRAMS

Amplifier/Power Supply Board Schematic, Drawing 261 x 216
Amplifier/Power Supply Board Component Layout, Drawing 261 x 219 (2 sheets)

Processor Board Schematic, Drawing 261 x 91
Processor Board Component Layout, Drawing 261 x 103 (2 sheets)

Calibration Board Schematic, Drawing 261 x 59
Calibration Board Component Layout, Drawing 261 x 59A

LCD Display Board Schematic, Drawing 261 x 58
LCD Display Board Component Layout, Drawing 261 x 209 (2 sheets)

Backplane Board Schematic, Drawing 261 x 60
Backplane Board Component Layout, Drawing 261 X 76A

RS-232 Board Schematic, Drawing 261 x 179
RS-232 Board Component Layout, Drawing 261 x 180

Wiring Diagram, Drawing 261 x 61

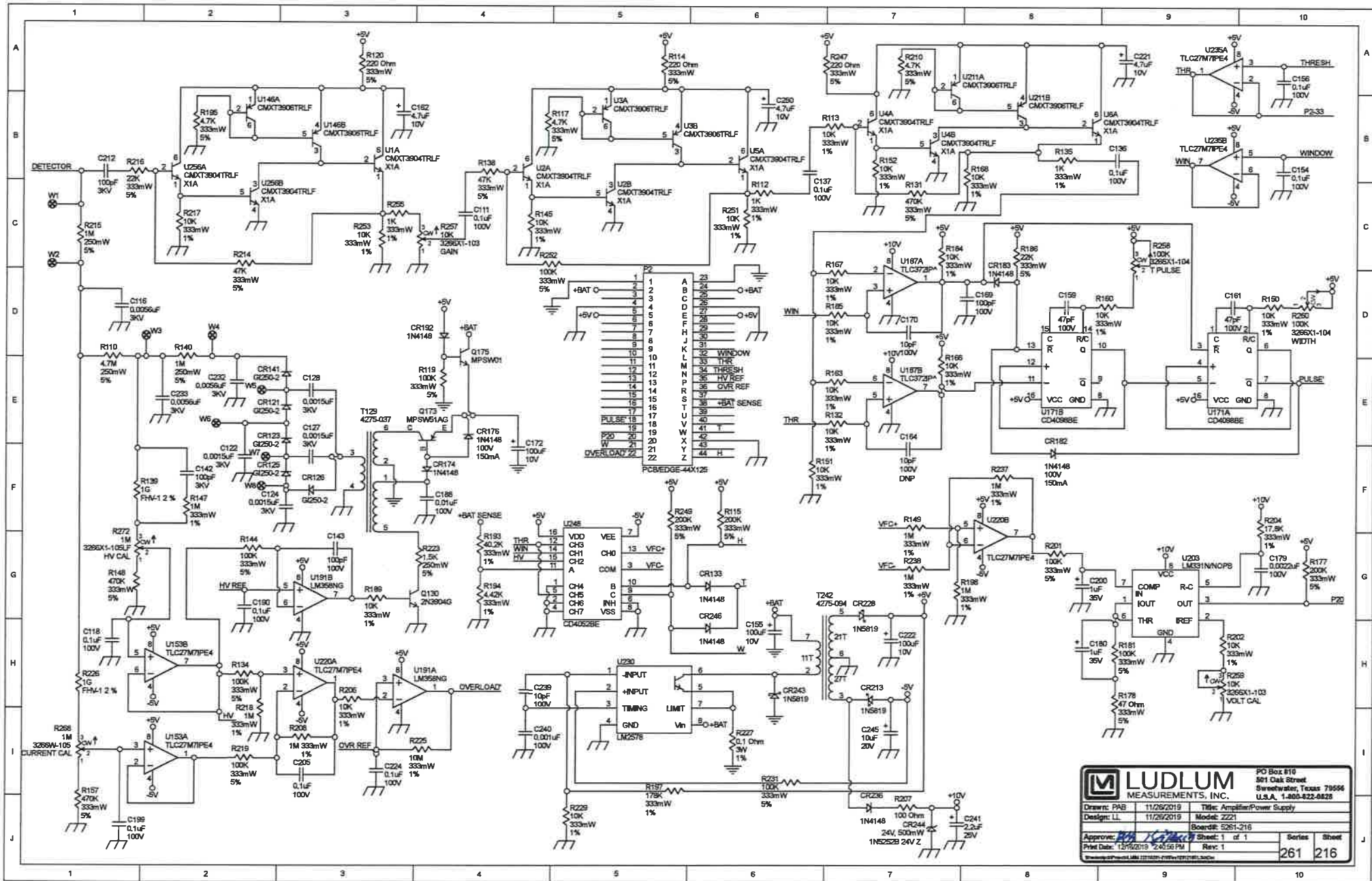

LUDLUM MEASUREMENTS, INC.
 PO Box 818
 801 Oak Street
 Sweetwater, Texas 79556
 U.S.A. 1.800.822.8828

Drawn: PAB	11/26/2019	Title: Amplifier Power Supply
Design: LL	11/26/2019	Model: Z221
Approved: [Signature]		Board#: 5261-216
Print Date: 12/16/2019 2:02:56 PM	Sheet: 1 of 1	Series: 2.2.2
		Rev: 1
		261 216

P2

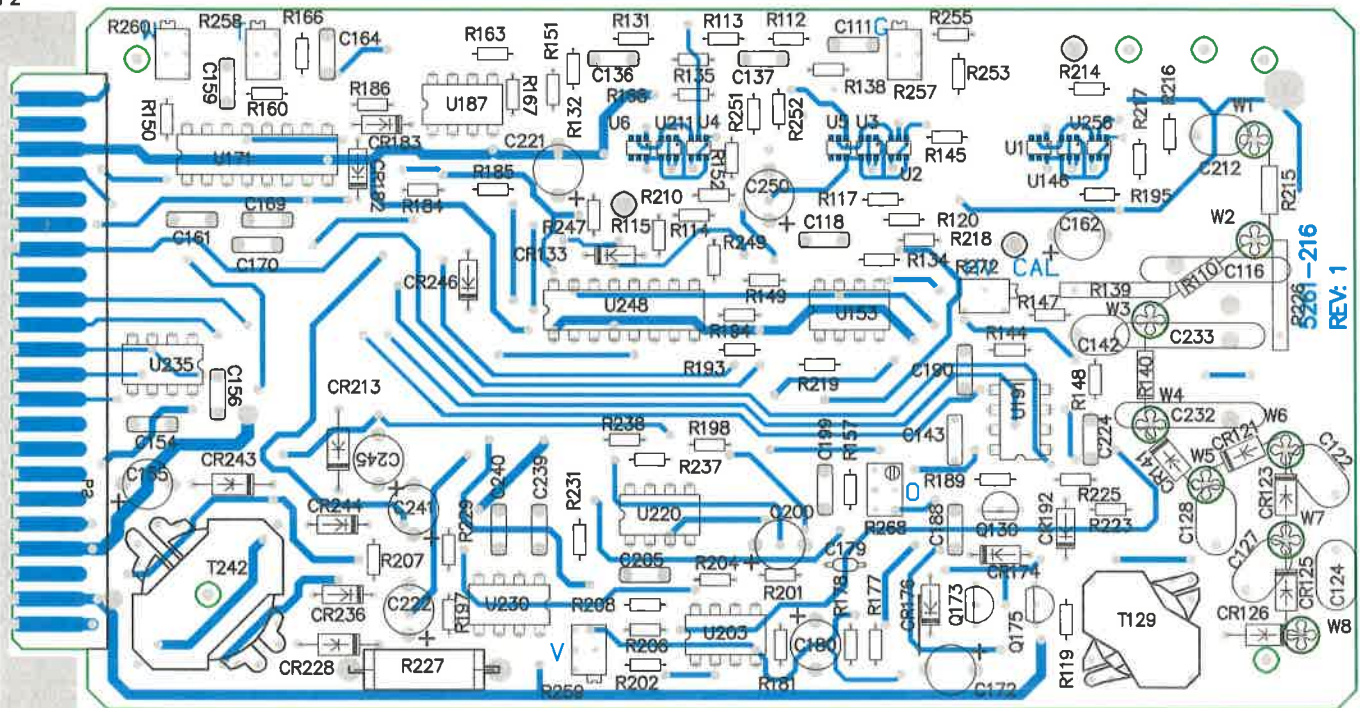

		PO Box 810 501 Oak Street Sweetwater, TX 79556 U.S.A. 1-800-622-0828	
Title: Amplifier/Power Supply			
Drawn: PAB	11/26/2019	Model: 2221	
Design: LL	11/26/2019	Board#: 5261-216	
Approve: ROS	10 JAN 20	Rev: 1	
PCBA Drawing		SCALE: 1.08	Series Sheet
Print Date: 1/10/2020 10:40:27 AM		Top Overlay	261 219
<small>\\freedom\pcb\Projects\MM\2221\5261-216\Rev1\261216R1_Assy_Pcb.Doc</small>			

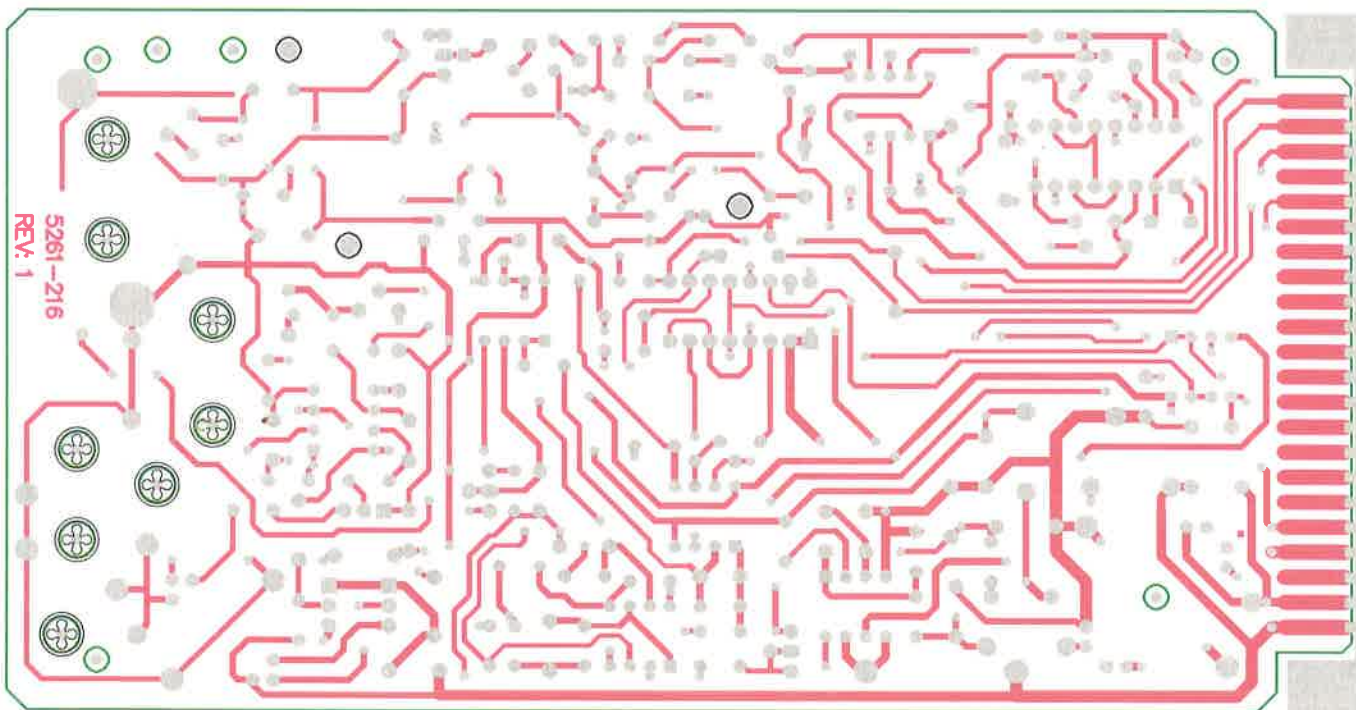

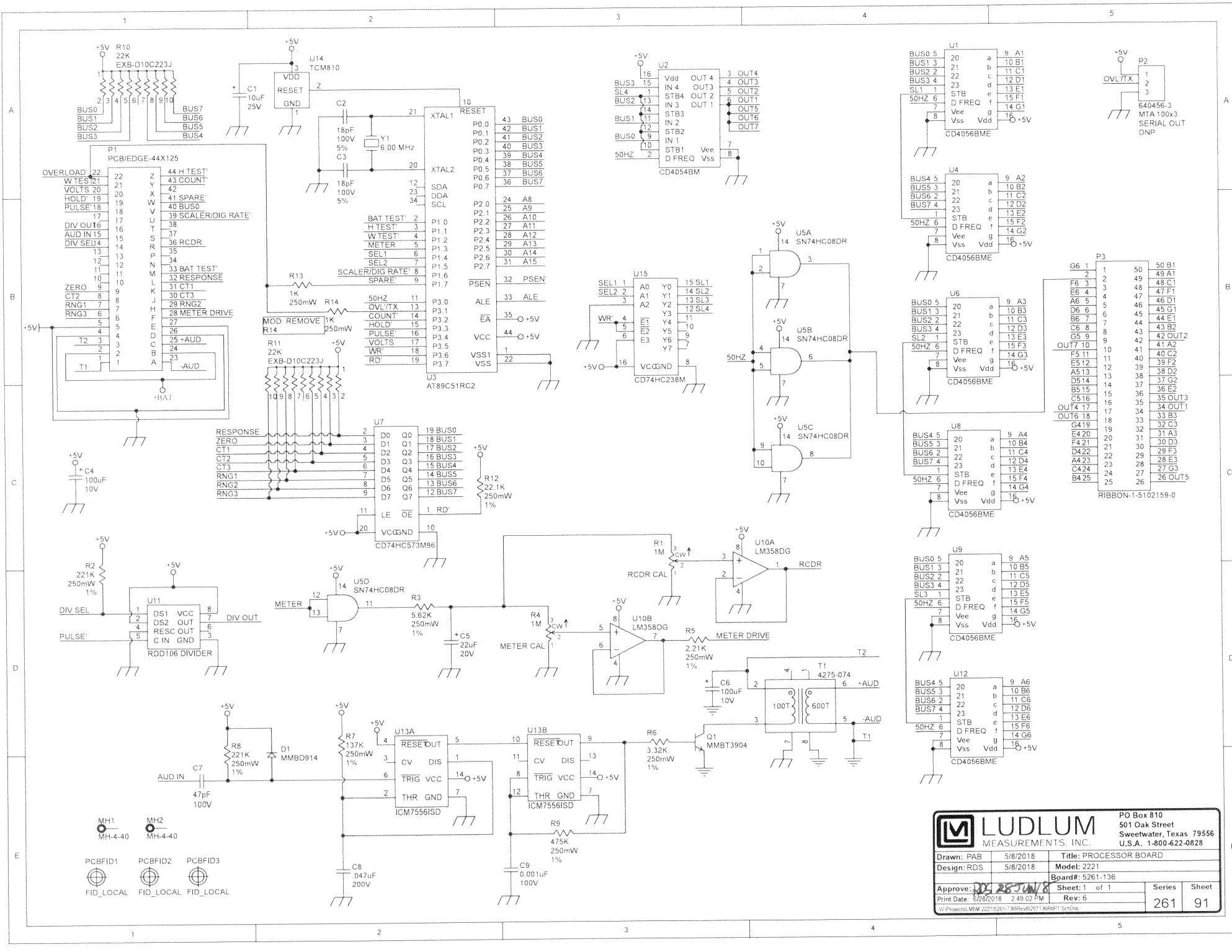

		LUDLUM		PO Box 810	
		MEASUREMENTS, INC.		501 Oak Street	
				Sweetwater, TX 79556	
				U.S.A. 1-800-622-0828	
Title: Amplifier/Power Supply					
Drawn: PAB	11/26/2019	Model: 2221			
Design: LL	11/26/2019	Board#: 5261-216			
Approve: <i>RDS 10 JAN 20</i>		Rev: 1			
PCBA Drawing		SCALE: 1.08	Series	Sheet	
Print Date: 1/10/2020 10:40:31 AM		Bottom Overlay	261	219	
<small>\\wreedom\pcb\Projects\LMM\2221\5261-216\Rev1\261216R1_Assy.PcbDoc</small>					

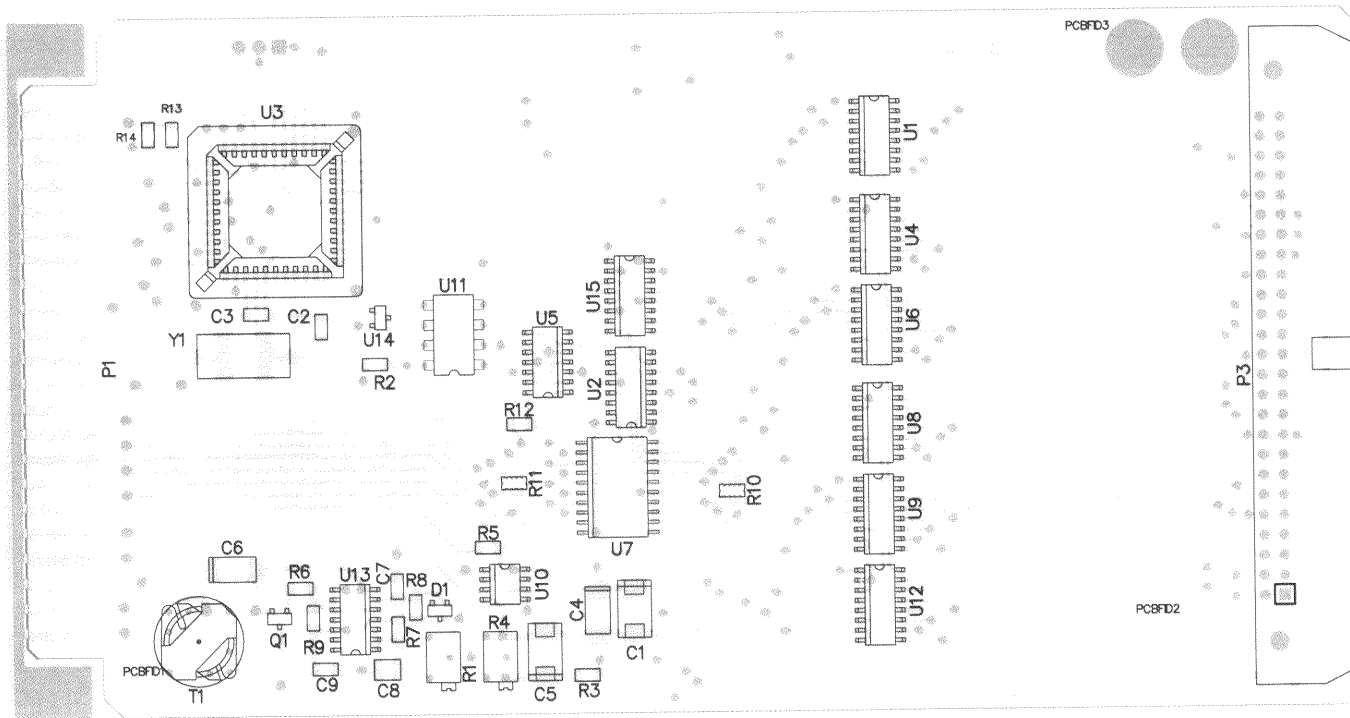

		PO Box 810 501 Oak Street Sweetwater, Texas 79556 U.S.A. 1-800-622-0828	
		Title: PROCESSOR BOARD	
Drawn: PAB Design: RDS	5/8/2018 5/8/2018	Model: 2221 Board#: 5261-136	Sheet: 1 of 1 Rev: 6
Approved: <i>[Signature]</i> Print Date: 5/28/2018 2:49:02 PM	Sheet: 1 of 1 Rev: 6	Series: 261	Sheet: 91

W:\Projects\MIM\2221\5261-136\Rev02\136R0P136rDoc



 LUDLUM MEASUREMENTS, INC.		PO Box 810 501 Oak Street Sweetwater, TX 79556 U.S.A. 1-800-622-0828	
		Title: PROCESSOR BOARD	
Drawn: PAB	5/8/2018	Model: 2221	
Design: RDS	5/8/2018	Board#: 5261-136	
Approve: <i>RDS</i>	<i>28 JUN 18</i>	Rev: 6	
Print Date: 6/28/2018 2:49:10 PM		SCALE: 1.08 Top Overlay	Series 261
		Sheet	103
W:\Projects\LMM 2221\5261-136\Rev6\261136R6 Assy.PcbDoc			

DO NOT PLACE P2

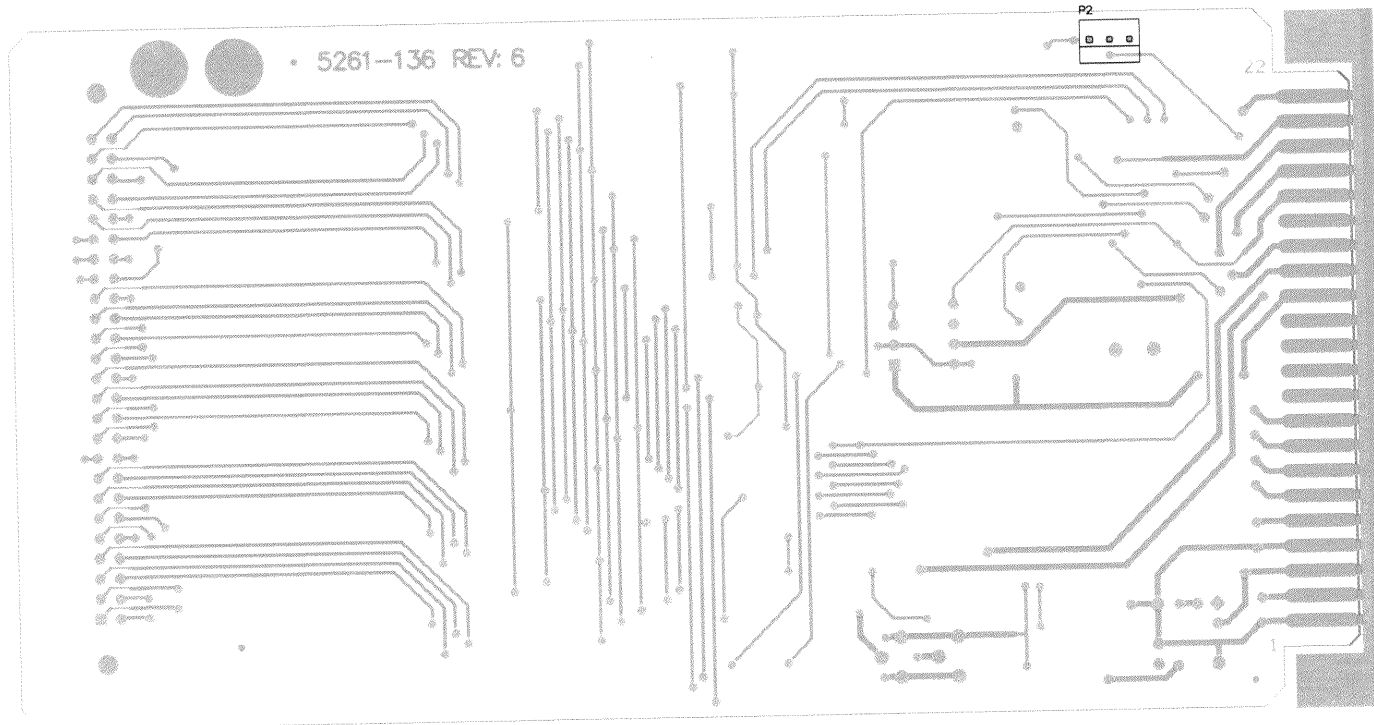

		PO Box 810 501 Oak Street Sweetwater, TX 79556 U.S.A. 1-800-622-0828	
Title: PROCESSOR BOARD			
Drawn: PAB	5/8/2018	Model: 2221	
Design: RDS	5/8/2018	Board#: 5261-136	
Approve: <i>RDS</i>	<i>28 JUN 18</i>	Rev: 6	
Print Date: 6/28/2018 2:49:15 PM		SCALE: 1.08 Bottom Overlay	Series Sheet 261 103
W:\Projects\LMRM 2221\5261-136\Rev6\261136R6 Assy.PcbDoc			

1

2

3

4

5

A

A

B

B

C

C

D

D

E

E

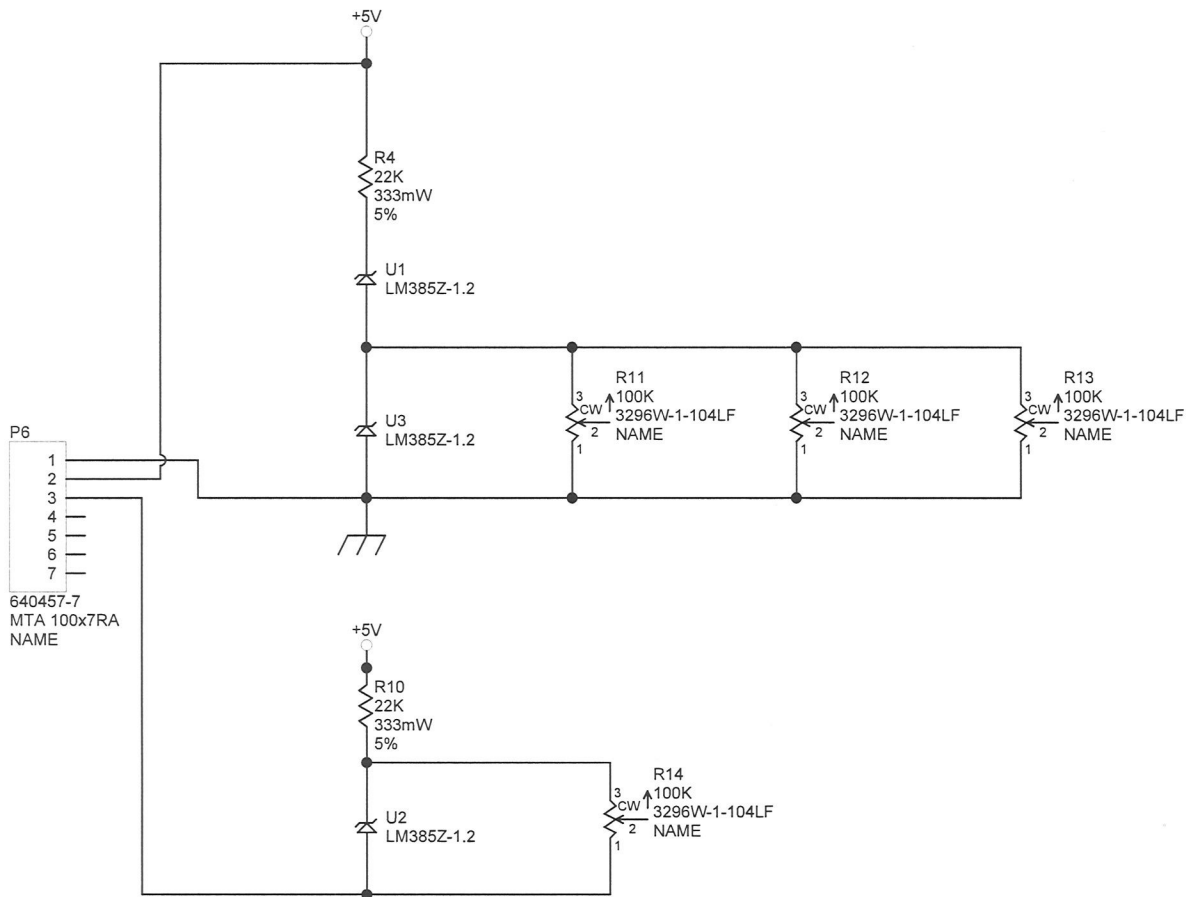

		PO Box 810 501 Oak Street Sweetwater, Texas 79556 U.S.A. 1-800-622-0828	
Drawn: LL	3/16/89	Title: Calibration Board	
Design: LL	3/16/89	Model: 2221	
		Board#: 5261-075	
Approve: <i>015128TAWIS</i>	Sheet: 1 of 1	Series	Sheet
Print Date: 1/27/2015 5:06:45 PM	Rev: 1	261	59
W:\Projects\LMIM 2221\5261-075\Rev1\261075R1.SchDoc			

1

2

3

4

5

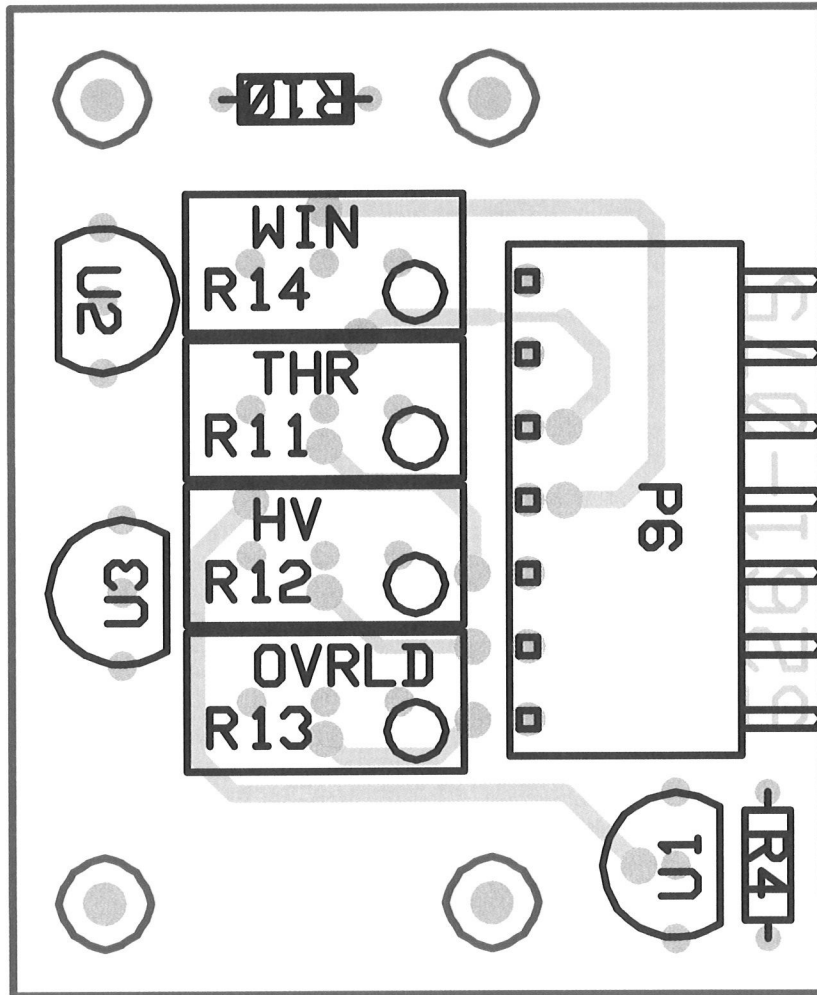

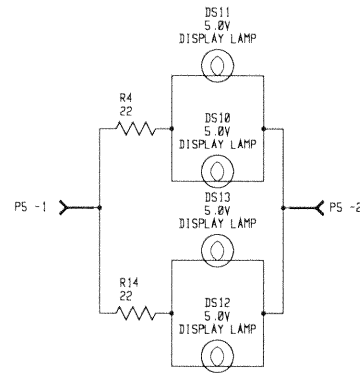
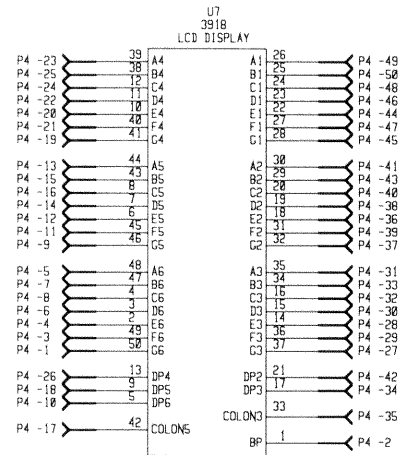

		PO Box 810 501 Oak Street Sweetwater, TX 79556 U.S.A. 1-800-622-0828	
		Title: Calibration Board	
Drawn: LL	3/16/89	Model: 2221	
Design: LL	3/16/89	Board#: 5261-075	
Approve: <i>RDS 8 JUL 14</i>		Rev: 1	
PCBA Drawing		SCALE: 1.00	Series
Print Date: 7/8/2014	11:17:46 AM	Top Overlay	Sheet 261 59A
<small>W:\Projects\LMIM 2221\5261-075\Rev1\261075R1_Assy.PcbDoc</small>			

REVISIONS				
EFF	AUTHORITY	ZONE	LTR	DESCRIPTION
				DATE
				APPROVED

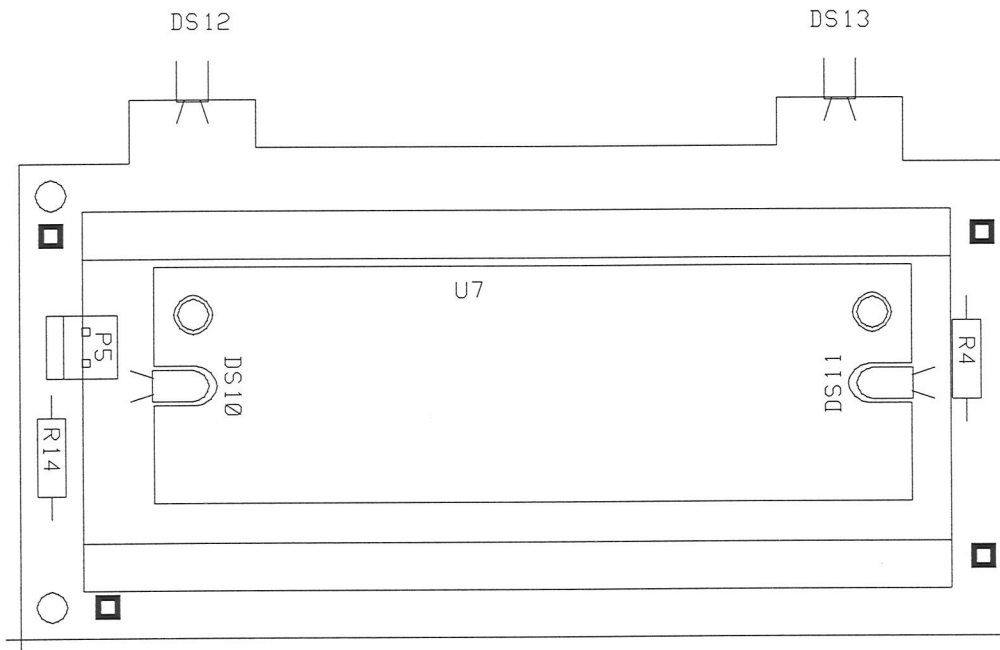

LUDLUM MEASUREMENTS INC.			
UPDATED	-	TITLE : LCD DISPLAY	
DR LL	3/16/89	BOARD# 5261-074	
CHK		SIZE	MODEL
DSGN LL	3/16/89	C	2221
APPD	<i>[Signature]</i>	SERIES	261
NEXT HIGHER ASSY		SHEET	58
14:47:32	28-Apr-88	58261074	OF 1



		LUDLUM MEASUREMENTS INC. SWEETWATER, TX.			
DR	LL	03/27/89	TITLE : DISPLAY BOARD		
			BOARD : 5261-074		
DSCN	LL	03/16/89	MODEL : 2221		
APP	<i>RJS</i>	<i>7 Nov 13</i>	FILENAME : BS261074		
COMPONENT		SOLDER		09:51:12	7-Nov-13
			REVISION	SERIES	SHEET
OUTLINE		OUTLINE	1.0	261	209

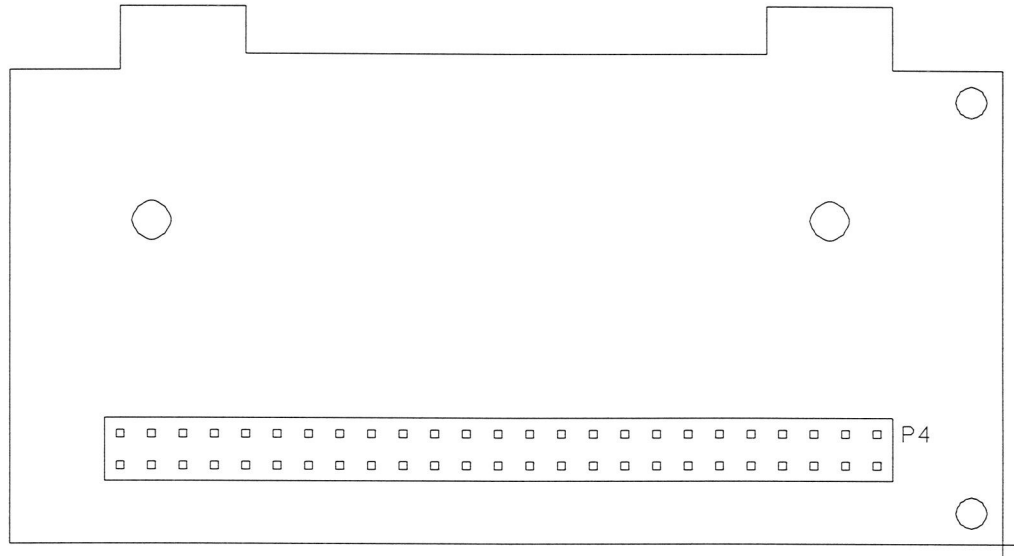

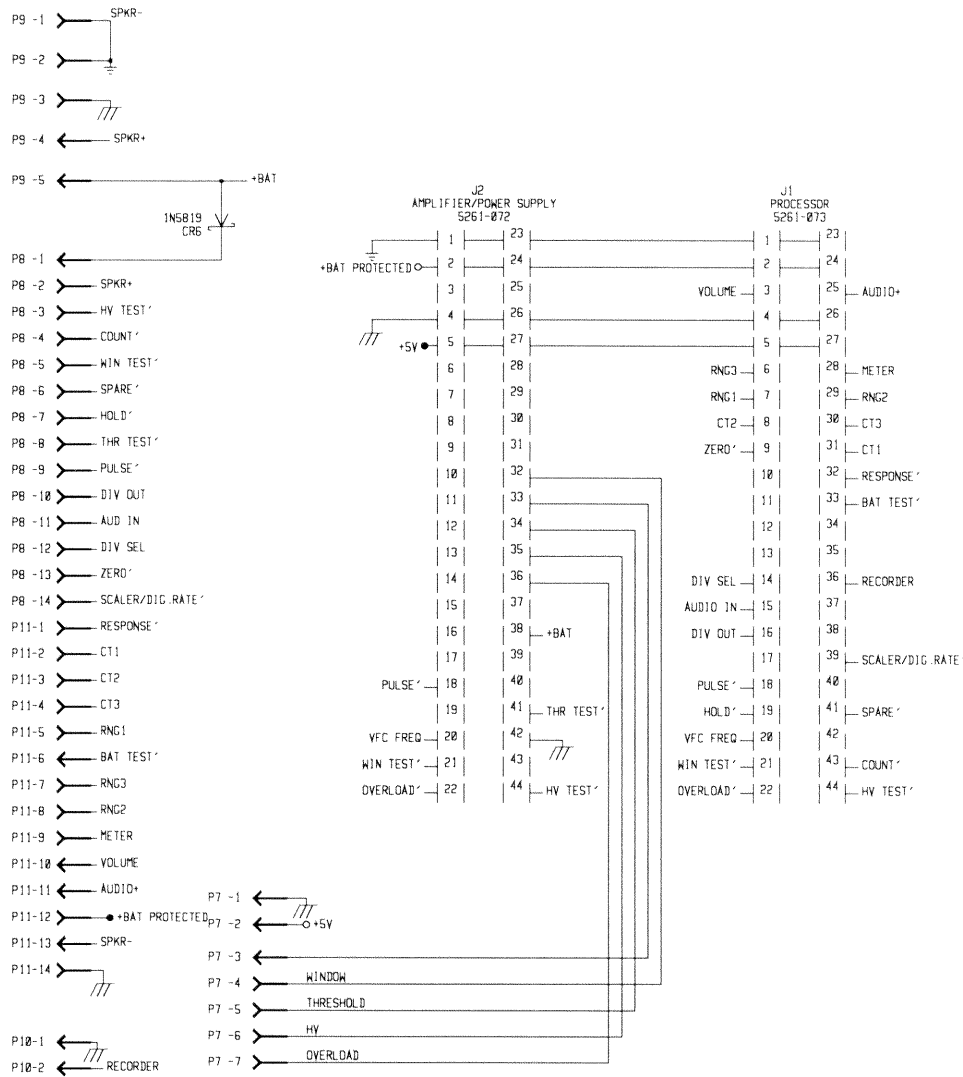

 LUDLUM MEASUREMENTS INC. SWEETWATER, TX.					
DR	LL	03/27/89	TITLE: DISPLAY BOARD		REV 1
			BOARD# 5261-074		FILE
DSCN	LL	03/16/89	MODEL 2221	SERIES 261	SHEET 209
APP	<i>RSS</i>	<i>Nov 13</i>	COMP ARTWORK <input type="checkbox"/>	SLDR ARTWORK <input type="checkbox"/>	
	00:00:00	00/00/00	COMP OUTLINE <input type="checkbox"/>	SLDR OUTLINE <input checked="" type="checkbox"/>	
COMP PASTE	<input type="checkbox"/>	COMP MASK	<input type="checkbox"/>	SLDR PASTE	<input type="checkbox"/>
		SLDR MASK	<input type="checkbox"/>		

REVISIONS				
EFF	AUTHORITY	ZONE	LTR	DATE

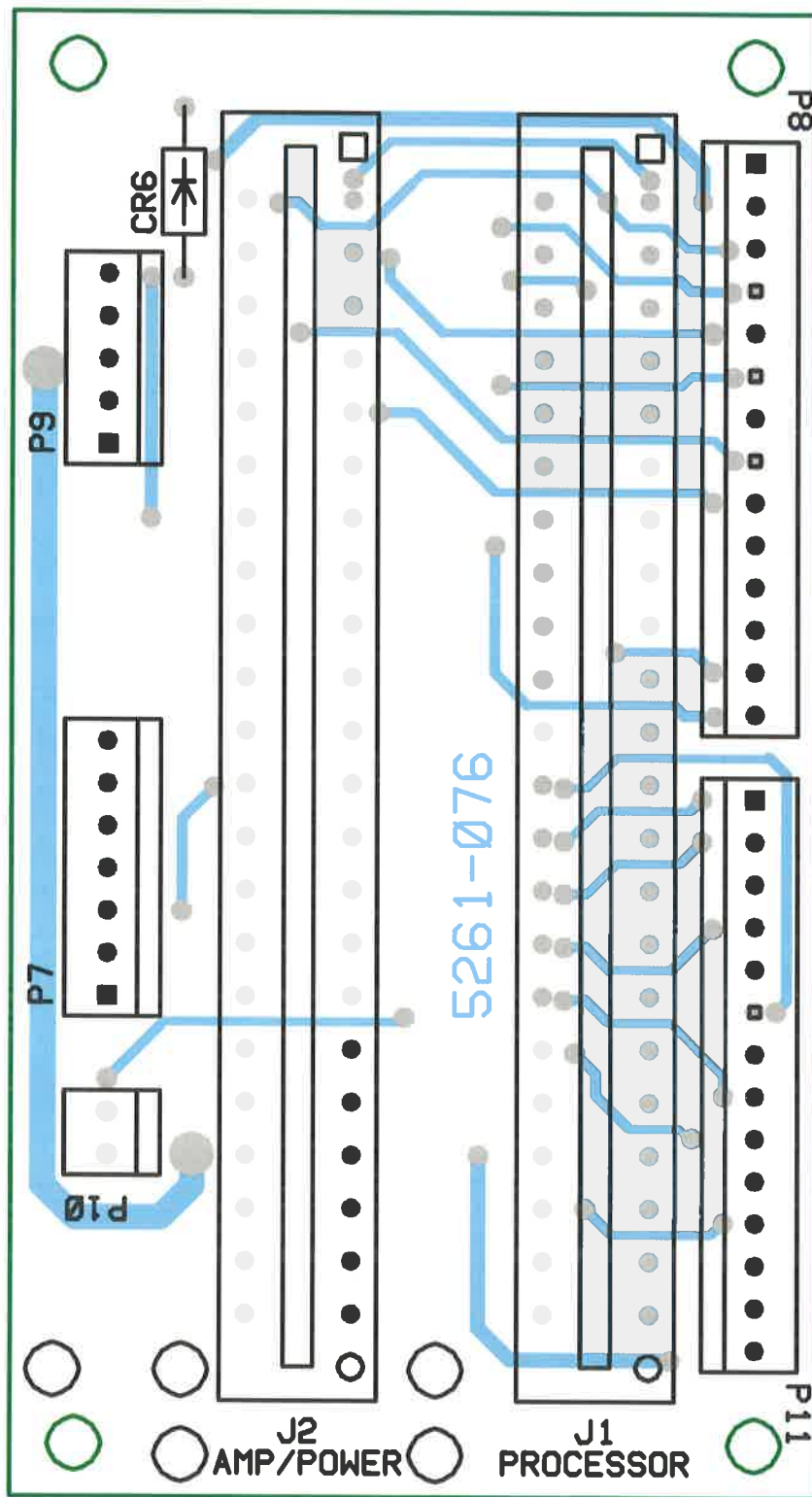

UPDATED	-	LUDLUM MEASUREMENTS INC.		
DR LL	3/16/89	TITLE: BACKPLANE		
DSON LL	3/16/89	BOARD# 5261-076		
APPD	<i>RJD</i>	SIZE	MODEL	SERIES
NEXT HIGHER ASSY.	<i>5261-076</i>	C	2221	261
14:57:34	22-May-88	5261076		SHEET 1 OF 1



 LUDLUM MEASUREMENTS, INC.		PO Box 810 501 Oak Street Sweetwater, TX 79556 U.S.A. 1-800-622-0828	
		Title: Backplane	
Drawn: LL	3/16/89	Model: 2221	
Design: LL	3/16/89	Board#: 5261-076	
Approve: <i>LL</i>	<i>3/22/89</i>	Rev: 1	
PCBA Drawing		SCALE: 1.08	Series Sheet
Print Date: 11/21/2018 9:12:03 AM		Top Overlay	261 76 <i>4</i>
<small>W:\freedom\pcb\Projects\LMM 2221\5261-076\Rev1\281076R1_Assy_PcbDoc</small>			

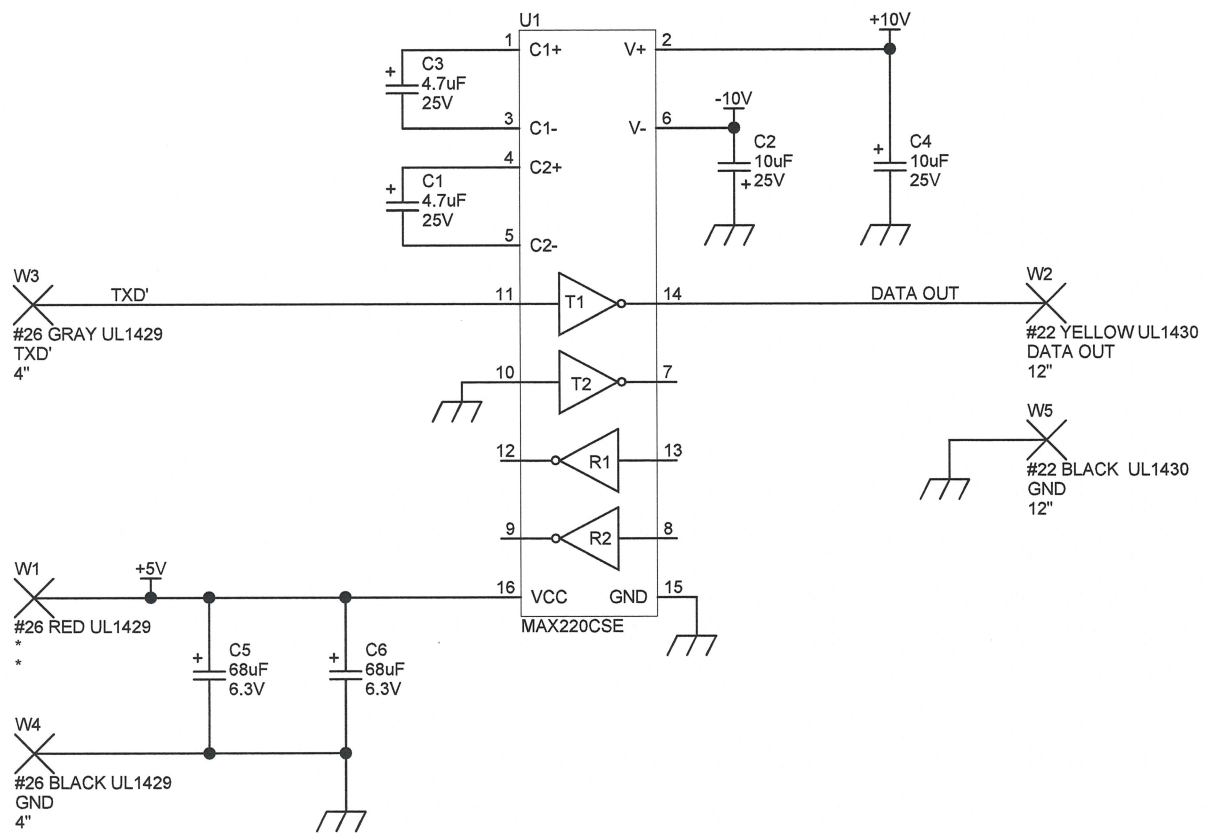

		PO Box 810 501 Oak Street Sweetwater, Texas 79556 U.S.A. 1-800-622-0828	
		Drawn: CKB Design: RDS Approve: <i>MS 11 Feb 13</i> Print Date: 2/8/2013 1:57:38 PM	Title: RS-232 BOARD Model: 2221 Board#: 5261-179 Sheet: 1 of 1 Rev: 1
<small>W:\Projects\LMIM 2221\5261-179\rev1.0\261179R1P1.SchDoc</small>			

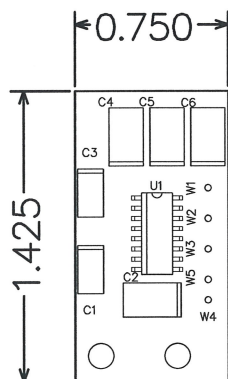

LUDLUM
MEASUREMENTS, INC.

PO Box 810
 501 Oak Street
 Sweetwater, TX 79556
 U.S.A. 1-800-622-0828

Title: RS-232 BOARD			
Drawn: CKB	03/21/2001	Model: 2221	
Design: RDS	11/11/1999	Board#: 5261-179	
Approve: <i>RDS</i>	<i>11/26/13</i>	Rev: 1	
Print Date:		SCALE: 1.00	Series
2/8/2013	1:57:39 PM	Top Overlay	261
			Sheet
			180

REVISIONS						
EFF	AUTHORITY	ZONE	LTR	DESCRIPTION	DATE	APPROVED

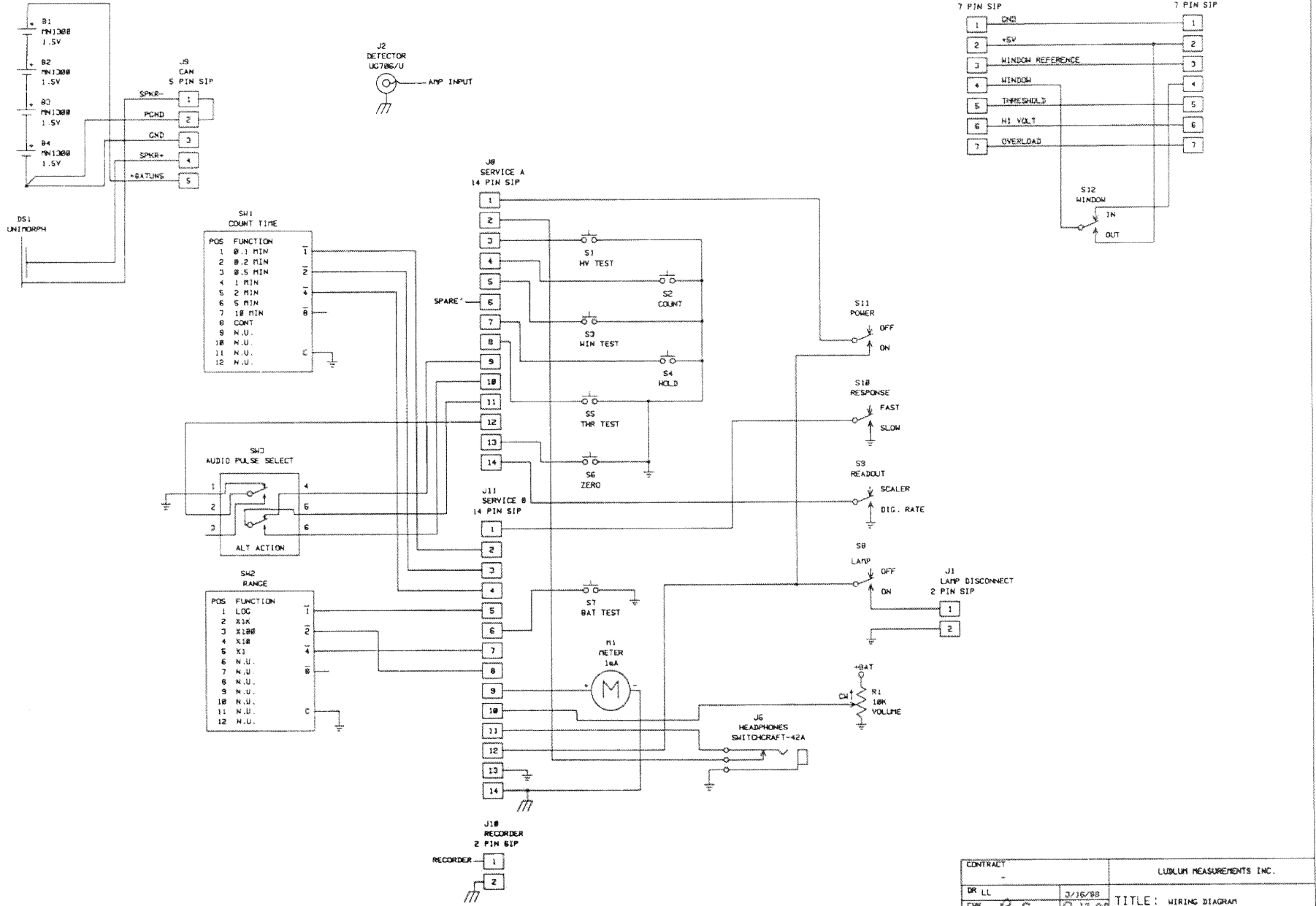

CONTRACT		LUDLUM MEASUREMENTS INC.			
DR LL	3/16/88	TITLE: WIRING DIAGRAM			
CHK	R.C. 7/13/88				
DSGN LL	3/16/88	BOARD# 261-877			
APPD	ESS 7/13/88	SIZE	MODEL	SERIES	SHEET
NEXT HIGHER ASST.		D	2221	201	61
18:41:85	85-88-88	S0261877.DWG			SHEET 1 OF 1

261 x 61