

**LUDLUM MODELS 375 (INCLUDING SERIES ONE),  
375/1, 375/2 AND 375/4**

**DIGITAL WALL-MOUNT AREA MONITORS**

**May 2023**

**Serial Number 356042 and Succeeding**

**Serial Numbers**

**LUDLUM MODELS 375 (INCLUDING SERIES ONE),  
375/1, 375/2 AND 375/4  
DIGITAL WALL-MOUNT AREA MONITORS**

**May 2023**

**Serial Number 356042 and Succeeding  
Serial Numbers**



**LUDLUM MEASUREMENTS, INC**  
501 OAK STREET, P.O. BOX 810  
SWEETWATER, TEXAS 79556  
325-235-5494, FAX: 325-235-4672



## **STATEMENT OF WARRANTY**

Ludlum Measurements, Inc. warrants the products covered in this manual to be free of defects due to workmanship, material, and design for a period of twelve months from the date of delivery. The calibration of a product is warranted to be within its specified accuracy limits at the time of shipment. In the event of instrument failure, notify Ludlum Measurements to determine if repair, recalibration, or replacement is required.

This warranty excludes the replacement of photomultiplier tubes, G-M and proportional tubes, and scintillation crystals which are broken due to excessive physical abuse or used for purposes other than intended.

There are no warranties, express or implied, including without limitation any implied warranty of merchantability or fitness, which extend beyond the description of the face there of. If the product does not perform as warranted herein, purchaser's sole remedy shall be repair or replacement, at the option of Ludlum Measurements. In no event will Ludlum Measurements be liable for damages, lost revenue, lost wages, or any other incidental or consequential damages, arising from the purchase, use, or inability to use product.

## **RETURN OF GOODS TO MANUFACTURER**

If equipment needs to be returned to Ludlum Measurements, Inc. for repair or calibration, please send to the address below. All shipments should include documentation containing return shipping address, customer name, telephone number, description of service requested, and all other necessary information. Your cooperation will expedite the return of your equipment.

**LUDLUM MEASUREMENTS, INC.  
ATTN: REPAIR DEPARTMENT  
501 OAK STREET  
SWEETWATER, TX 79556**

**800-622-0828    325-235-5494  
FAX 325-235-4672**

REVISION HISTORY

REV	DESCRIPTION	DATE	BY
1	VALID	11/11/2010	CMC
2	REMOVED SIDE VIEW	5/4/2011	CMC
3	ADDED NOTES	2014-01-22	JLG
4	ECF# 6537	9-12-22	CMC

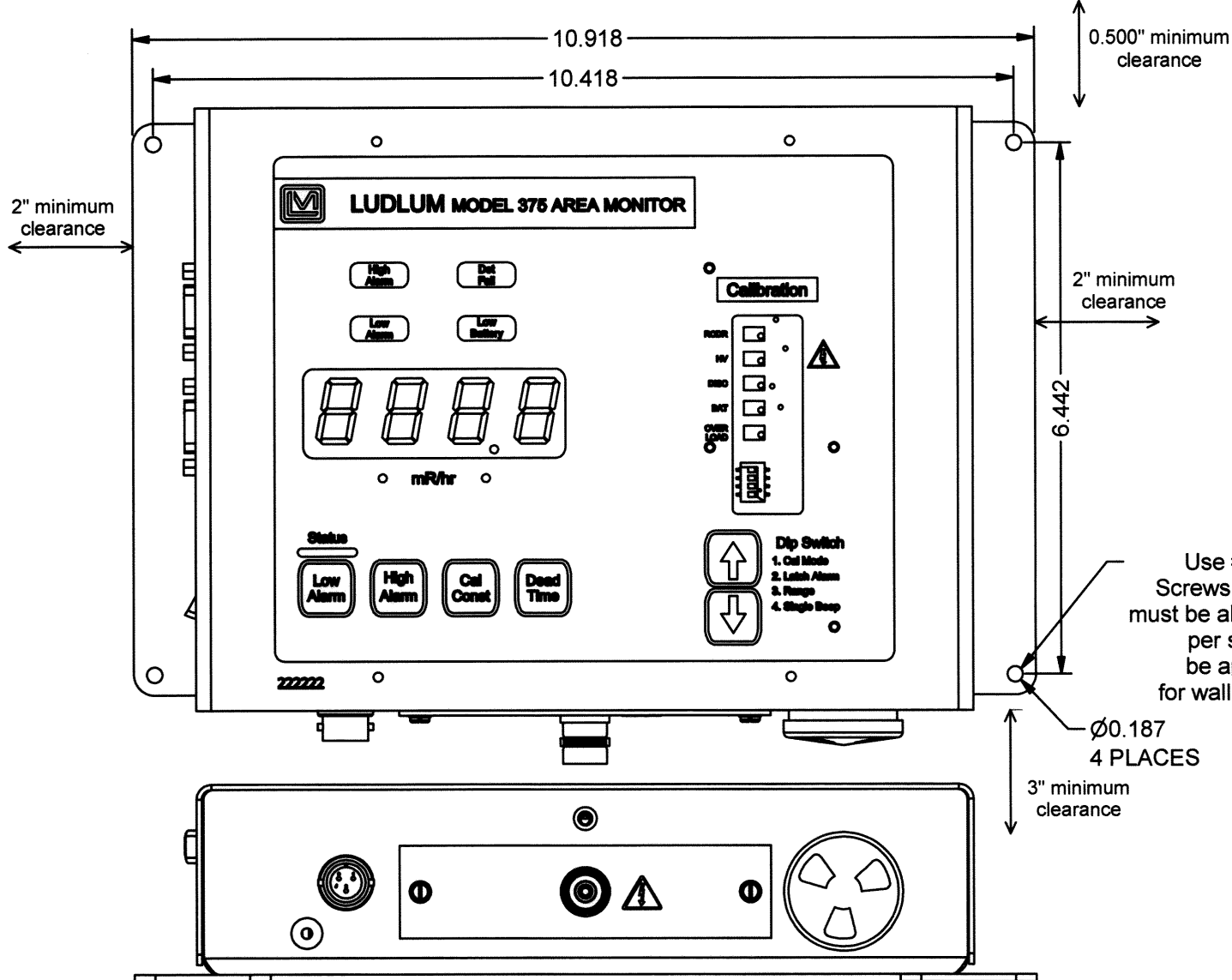
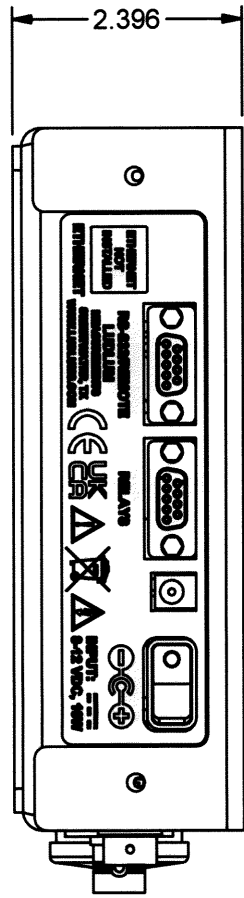

Use #6 screws.  
Screws and anchors  
must be able to hold 12lbs  
per screw and  
be appropriate  
for wall construction.

DWN	DATE	CHK	DATE	APP	DATE
CMC	9-12-22			<i>WJM</i>	9-12-22
<b>DWG NUM: 4558-004</b>				<b>SCALE: 1/2</b>	
<b>TITLE M 375 OVERALL VIEW (2010)</b>					
LUDLUM MEASUREMENTS, INC. 501 OAK STREET SWEETWATER, TEXAS 79556		SERIES	SHEET		
		558	4		

# Table of Contents

---

<b><i>Introduction</i></b>	<b>1</b>
<b><i>Getting Started</i></b>	<b>2</b>
External Detector (Option)	2-1
Power Up	2-1
Radiation Units	2-2
Checking Parameters	2-2
*Model 375 Series One	2-3
Setting Alarm Points	2-3
Operational Check	2-4
Return for Repair and Calibration	2-5
<b><i>Specifications</i></b>	<b>3</b>
<b><i>Operator Controls and Setup</i></b>	<b>4</b>
Calibration Controls	4-1
Dipswitch (under calibration cover)	4-2
RS-232 Output	4-3
9-Pin Remote Data Connector	4-3
9-Pin Relays Connector	4-4
Typical Internal Detector Setups	4-4
<b><i>Common Options and Modifications</i></b>	<b>5</b>
Relay Options	5-1
Ethernet Interface Option	5-5
Time and Date Stamp Option	5-5
Printer DIP Switch Settings	5-6
Sigma Alarm Modification Option	5-7
4 to 20 mA Isolated Output Driver Option	5-8
<b><i>Safety Considerations</i></b>	<b>6</b>
Environmental Conditions for Normal Use	6-1
Cleaning Instructions and Precautions	6-1
Warning Markings and Symbols	6-2
Electrical Safety Precautions	6-3
Detector Connector	6-4
Battery Replacement	6-4
<b><i>Calibration</i></b>	<b>7</b>
High Voltage	7-1

<b>Calibration Parameters</b>	<b>7-1</b>
<b>Analog Output</b>	<b>7-2</b>
<b>Discriminator</b>	<b>7-2</b>
<b>Battery Charge</b>	<b>7-3</b>
<b><i>Recycling</i></b>	<b><i>8</i></b>
<b><i>Parts List</i></b>	<b><i>9</i></b>
<b>Model 375 Digital Wall-Mount Area Monitor without Detector</b>	<b>9-1</b>
<b>Model 375/1 Digital Wall-Mount Area Monitor</b>	<b>9-1</b>
<b>Model 375/2 Digital Wall-Mount Area Monitor</b>	<b>9-1</b>
<b>Model 375/4 Digital Wall-Mount Area Monitor</b>	<b>9-1</b>
<b>Model 375 Series One without Detector</b>	<b>9-1</b>
<b>Model 375/2 Series One</b>	<b>9-1</b>
<b>Model 375/4 Series One</b>	<b>9-1</b>
<b>Main Board, Drawing 558 x 1</b>	<b>9-1</b>
<b>Wiring Diagram, Drawing 558 x 136</b>	<b>9-6</b>
<b>Internal Detectors</b>	<b>9-6</b>
<b><i>Drawings and Diagrams</i></b>	<b><i>10</i></b>
<b><i>Ethernet Network Settings for Model 375 Series, 375P, and 4525/4530 A</i></b>	
<b>Modes of Operation</b>	<b>A-1</b>
<b>Finding the Instruments on the Network</b>	<b>A-2</b>
<b>Network Settings</b>	<b>A-3</b>
<b>Common Settings</b>	<b>A-5</b>
<b>Password Settings</b>	<b>A-6</b>
<b>Model 375 TCP Mode</b>	<b>A-6</b>
<b>Model 375 UDP Mode</b>	<b>A-7</b>
<b>Model 4525 Mode</b>	<b>A-8</b>

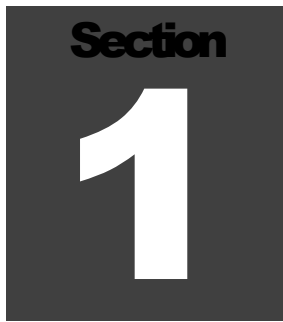
A dark gray square graphic with the word "Section" in white at the top and a large white number "1" in the center.

## Introduction

---

The Model 375 Digital Wall-Mount Area Monitor is designed for visibility and ease of use. Featuring a wall-mount chassis, the Model 375 has a four-digit LED display that is readable from 9.1 m (30 ft) away. Backlit indicators warn of low-radiation alarm (yellow), high-radiation alarm (red), instrument failure (red), and low battery (yellow). A green status light is a positive indication of instrument operation.

Parameters are protected under a calibration cover. Calibration is easily accomplished by moving the cal dipswitch to the right, and using the pushbuttons to increment or decrement the calibration constant, dead time correction, and alarm point parameters. Parameters are stored in non-volatile memory (retained even with power disconnected).

A five-decade logarithmic analog output is provided. A battery backup provides 48 hours of additional use after the primary power is removed. Depending on the needs of the customer, the Model 375 comes equipped with an internal detector or a connector for use with an external detector. The Model 375/1 comes equipped with an internal CsI scintillator detector. The Model 375/2 and 375/4 come equipped with internal, energy-compensated GM detectors.

The Ludlum Model 375 Series One is a Model 375 with modified firmware. Changes include certain display values in decimal points and units. Details can be found in sections “Getting Started” and “Specifications.”

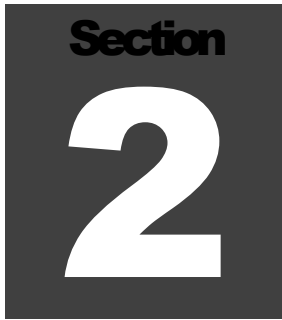

A dark gray square with the word "Section" in white at the top and a large white number "2" in the center.

## Getting Started

---

The Model 375 Digital Wall-Mount Area Monitor is designed for ease of use. This section of the manual is designed to help the first-time user get started. Initial power-up and basic features of the Model 375 will be discussed in this section. Other sections of the manual provide more detailed information.

### External Detector (Option)

**Warning!**

Potential electrical shock hazard - Do not touch the center pin of the detector connector unless the unit has turned off and power has been removed for at least one minute.

The Model 375 comes equipped with either an internal detector or a connector for use with an external detector. If your Model 375 is equipped with a connector on the bottom side of the chassis, an external detector is required. If you have an external detector, use the cable provided to connect it to the Model 375.

**Note:**

Splicing or re-terminating cables must be done carefully. Improper termination will result in the “shorting out” of the detector voltage, a DET FAIL, and/or blown-fuse condition.

### Power Up

Plug the wall-mount 9 Vdc power supply into a suitable wall (Mains) outlet.

Please set the alarm point(s) on this instrument to conform to your requirements. The factory-set alarm points may be incorrect for your use.

Refer to the instrument manual for more information on setting alarm points.

**FAILURE TO RESET THE ALARM POINT(S)  
MAY RESULT IN EXCESSIVE ALARMS OR  
LACK OF SENSITIVITY.**

If the RS-232 feature is used, plug in a suitably wired 9-pin connector cable. (See Page 4-4 for the pin assignment of the 9-pin connector.) Turn power ON with the left side panel switch. Do not turn power OFF unless the unit is to be removed from service.

Read and then remove the sticker (illustrated to the left) from the instrument calibration cover. Checking and setting of the alarm point(s) is discussed in detail below and on pages 2-3 and 7-1 of this manual.

Initial power-up will momentarily activate the internal front-panel lights, sound the audio, and display "8888" on the 4-digit LED display. The firmware version number (396Nyy) is then displayed as "396" and "xyyy" (where xx and yy represents the current version number).

When the instrument has finished measuring background, it will display the current radiation reading and begin checking for an alarm condition.

## Radiation Units

The Model 375 may be calibrated for almost any desired radiation units of measure. Common units of measure include mR/hr,  $\mu$ R/hr, R/hr, mSv/h,  $\mu$ Sv/h, cps, cpm, and kcpm. In each case, the unit of measure is indicated underneath the four-digit display. Throughout the rest of this manual, the notation <units> will be used as a substitute.

## Checking Parameters

Check the low alarm point setting by pressing the LOW ALARM button. The low alarm point will be displayed as long as the button is pressed. The low alarm point is in units of <units>. The low alarm point can be set from 0.1 <units> to 9999 <units>\*.

Check the high alarm point setting by pressing the HIGH ALARM button. The high alarm point will be displayed as long as the button is pressed. The high alarm point is in units of <units>. The high alarm point can be set from 0.1 <units> to 9999 <units>\*.

Check the calibration constant by pressing the CAL CONST button. The calibration constant will be displayed as long as the button is pressed. The calibration constant is in units of cpm (counts per minute) per <units>\*. The calibration constant can be set from 0.1 cpm/<units> to 9999 cpm/<units>\*.

Check the detector dead time correction by pressing down on the DEAD TIME button. The dead time correction will be displayed as long as the button is pressed. The dead time correction is in units of microseconds\*. The dead time correction can be set from 0.1 microseconds to 9999 microseconds\*.

\* **Model 375 Series One:** In the special case of the Model 375 Series One, make note of the following changes resulting from firmware modification:

With the RANGE dipswitch in the left position, two decimal places will be displayed.

With the RANGE dipswitch in the right position, no decimal place will be displayed.

Calibration constant will be displayed in cps per unit, instead of cpm per unit.

Dead Time Correction will display in  $10^{\text{th}}$ s of microseconds (i.e. 50  $\mu\text{sec}$  instead of 5  $\mu\text{sec}$ ).

## Setting Alarm Points

The LOW ALARM and HIGH ALARM points can only be changed while the instrument is in calibration mode. Switch the top dipswitch CAL MODE (behind the calibration cover) to the right to place the instrument into calibration mode.

Changing alarm points is done by holding down the corresponding parameter key and pressing the up or down arrow buttons. Alarm points can be set in the range of 0.1 to 9999\*. When an alarm point is changed, the instrument will sound an audible beep to confirm the saving of the parameter, and will then return to displaying the current radiation level.

### Note:

Once the alarm point(s) is set, it is important to remember to switch the CAL MODE switch back to the left. This action protects the parameters from inadvertent changes.

## Operational Check (optional)

The operational check is an important assurance that the radiation detector and electronics are working correctly.

**Note:**

Ludlum Measurements suggests that an operational check be performed on a regular basis. Local procedures may supersede this suggestion.

For an operational check, it is necessary to use a radiation check source (not included, but available). When not being used, store the check source in a secure area.

**Note:**

LMI check sources present very minimal risks and are therefore unlicensed (Exempt Quantity Sources reference: 10 CFR 30.71 Schedule B). The radioactive element is sealed (permanently bonded or fixed inside a capsule) so you need not wash your hands after handling. Radiation exposure while handling this source is very minimal with no identified long or short term risks. Although the amount of radiation given off by exempt sources is so low that it presents no significant hazard, they should be handled with care and respect. Time, distance, and shielding are the best ways to control exposure.

1. Taking the source in hand, place it so that it is located on or near the center (same location each time) of the detector. (For internal detector models, a metal plate on the bottom of the chassis identifies the location of the internal detector.) Hold it there for approximately five seconds or until the reading stabilizes. Take note of the displayed level of radiation.
2. Verify that the reading is within 20% of the last reading obtained. Remove the source from the detector.
3. If an alarm is activated, ensure that all visual and audible devices (if applicable) work correctly.

## Return for Repair and Calibration

To return an instrument for repair or calibration, provide sufficient packing material to prevent damage during shipment.

Every returned instrument must be accompanied by an **Instrument Return Form**, which can be downloaded from the Ludlum website at [www.ludlums.com](http://www.ludlums.com). Find the form by clicking the “Support” tab and selecting “Repair and Calibration” from the drop-down menu. Then choose the appropriate Repair and Calibration division where you will find a link to the form.

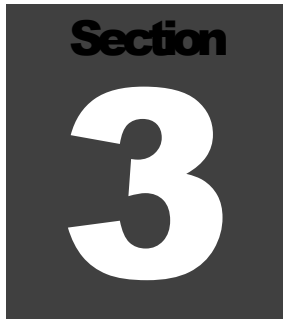
A dark gray square with the word "Section" in white at the top and a large white number "3" in the center.

## Specifications

---

**Compatible Detectors:** GM, proportional, and scintillation

**Display:** four-digit LED display with 2 cm (0.8 in.) character height

**Display Range:** 000.0-9999 (Series One: 00.00-9999)

**Display Units:** can be made to display in  $\mu\text{R/hr}$ ,  $\text{mR/hr}$ ,  $\text{R/hr}$ ,  $\mu\text{Sv/h}$ ,  $\text{mSv/h}$ ,  $\text{Sv/h}$ ,  $\mu\text{rem/hr}$ ,  $\text{mrem/hr}$ ,  $\text{rem/hr}$ ,  $\text{cpm}$ ,  $\text{cps}$ , and others

**Linearity:** readings within 10% of true value with detector connected

**Operating Range:** depends upon the type of detector used. The operating range of the 375/2 is from 1  $\mu\text{Sv/h}$  to 10  $\text{mSv/h}$  (0.1  $\text{mR/hr}$  to 1  $\text{R/hr}$ ). The operating range of the 375/4 is from 0.01  $\text{mSv/h}$  to 100  $\text{mSv/h}$  (1  $\text{mR/hr}$  to 10  $\text{R/hr}$ ). External detectors will have different operating ranges.

**Response:** typically 3 seconds from 10% to 90% of final reading

**Status (green light):** indicates the instrument is functioning properly

**Low Alarm:** indicated by a yellow light and slow beep (1 per second) audible tone (can be set at any point from 0.0-9999 {00.00-9999 for Series One})

**High Alarm:** indicated by a red light and a fast beep (4 per second) audible tone (can be set at any point from 0.0-9999 {00.00-9999 for Series One})

### Note:

Audible indicators can be configured as a single beep by dipswitch if desired. Audio intensity is controlled by rotating the baffle on the audio device. Audio intensity may also be adjusted by moving an internal connector.

**DET Fail:** indicated by a red light and an audible tone greater than 68 dB at 6.1 ft (2 m) for conditions of detector overload, no count from detector or instrument failure

**Low Bat:** indicated by a yellow light, beginning when two hours of battery life remain

**Connector:** series "C" (others available)

**Ethernet (optional):** 10 Base-T connection for use with Ludlum software

**Calibration Controls:** accessible from the front of instrument (protective cover provided)

**High Voltage:** adjustable from 450-2500 volts

**Dead Time:** adjustable to compensate for dead time of the detector and electronics (can be read on the display)

**Overload:** a display reading of -OL- and audible FAIL alarm indicate detector saturation. It is normally set to initiate just above the highest range of the detector.

**Over-range:** A display reading of "----" and activated low and high alarms indicate that the radiation field being measured has exceeded the counting range of the instrument (or when dead time correction accounts for more than 75% of the displayed reading).

**Data Output:** A 9-pin connector with female sockets provides five-decade log output, RS-232 output, signal ground connection, FAIL and HIGH ALARM signals (current sink), and direct connection to battery and ground

**Relays:** A 9-pin connector with male pins provides connection to three fail-safe form C relays, activated by the LOW ALARM (alert) High ALARM, and instrument FAIL. These contacts are potential-free (non-powered), but can handle 125 Vac at 0.3 A or 30 Vdc at 1 A.

**RS-232 Output:** a 2-second dump for computer data logging

**Remote (optional):** Ludlum Model 271 or 272 remote units

**Audio:** Intensity can vary from approximately 68 dB to 100 dB through operation of the external rotary baffle and the internal voltage connection. Frequency is approximately 3 kHz.

**Power:** 9 Vdc wall-mount adapter, handles any mains voltage in the world, supplied with four sets of prongs for almost any style wall receptacle

**Battery Life:** typically 48 hours in non-alarm condition; 12 hours in alarm condition

**Battery Charger:** battery is continuously trickle charged when the instrument is connected to line power and turned on

**Warning!:**

Only certified technician or calibration personnel should replace battery.

**Environmental Rating:** NEMA (National Electrical Manufacturers Association) rating of 1; IP (Ingress Protection) rating of 40. (Protective enclosures are available for harsher environments.)

**Construction:** aluminum housing with ivory powder-coat finish

**Size:** 18.7 x 24.6 x 6.4 cm (7.4 x 9.7 x 2.5 in.) (H x W x D)

**Weight:** 2.1 kg (4.7 lb)

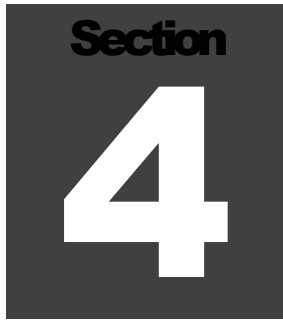

A dark gray square containing the word "Section" in a white sans-serif font at the top, and a large white number "4" in the center.

## Operator Controls and Setup

---

### Calibration Controls

Remove the calibration cover to expose the calibration controls.

**Warning!**

Do not touch the circuit board in the calibration window due to potential for electric shock.

The calibration controls include the up/down buttons, five calibration potentiometers, and the option dipswitch (detailed in the following subsection). The five potentiometers are detailed below.

**ANALOG:** used to adjust the logarithmic analog voltage output. Adjusted in calibration mode to the full-scale voltage reading or adjusted to a known point at some given reading.

**HV:** used to set the high voltage required for detector operation. Adjustable from 450-2500 Vdc. The high voltage required will depend on the type of detector used. Internal GM detectors typically require 550 Vdc. Be sure to check the high voltage with a high impedance (1000-Mohm impedance) voltmeter only. A high-voltage checkpoint is located next to the HV potentiometer.

**DISC:** internal discriminator used to set negative pulse threshold for counting pulses from the detector. Pad allows direct measurement of threshold voltage. Utilize a Ludlum Model 500 Pulser or equivalent to inject pulses of the desired threshold size. The pulse height threshold is adjustable from 2.0 mVdc to 100 mVdc.

**BAT CHARGE:** used to set the backup battery trickle charging voltage. It is set to 6.9 Vdc while the battery is disconnected.

**OVERLOAD:** used to set the detector current overload point. When excessive radiation causes the detector to overload, this set point will cause the FAIL light to engage, and the display will be forced to -OL-.

## Dipswitch (under calibration cover)

When the calibration cover is removed, a four-pole dipswitch is accessible that can activate or deactivate options. These four options are CAL MODE, LATCH ALARM, RANGE, and SINGLE BEEP.

**Dipswitch 1:** Switching the top **CAL MODE** switch to the right places the instrument into calibration mode. Parameters can only be changed while the instrument is in calibration mode. Calibration mode also changes the analog output to full-scale so that the full-scale voltage may be set by the ANALOG potentiometer. Calibration mode also slows the response time of the display and increases the accuracy. If the display seems too erratic, leaving this switch in the calibration mode during operation will help. Moving the CAL MODE switch back to the left locks the parameters and disables any further changes.

**Dipswitch 2:** The second switch, **LATCH ALARM**, changes the high alarm to a latching alarm. This switch does not affect the low alarm, which is always non-latching. When switched to the left, the high alarm is non-latching; the alarm automatically turns off when the radiation level drops below the alarm point. When switched to the right, the high alarm light and audio signals are latched until either the LOW ALARM or HIGH ALARM button is pressed.

**Dipswitch 3:** The third switch, **RANGE**, selects the range of the instrument. To select the 0.1 <units> - 999.9 <units>\* range, switch the RANGE switch to the left. To select the 1 <units> - 9999 <units>\* range, switch the RANGE switch to the right.

**Dipswitch 4:** Switching the fourth switch to the right places the instrument into **SINGLE-BEEP** mode. This option limits the audio output to a single half-second beep on LOW ALARM and HIGH ALARM. DET FAIL audio output (steady tone) is not limited.

\* See note on page 2-3 regarding Model 375 Series One.

## RS-232 Output

With the CAL MODE dipswitch in the left position, the Model 375 dumps RS-232 data onto pin 4 of the 9-pin connector every two seconds. The communication parameters are 2400 baud, 8 data bits, no parity, 1 stop bit, and no hardware handshaking.

The RS-232 data includes the current radiation readings and the current condition of the status lights. The data is presented in the following format:

BYTE1	0	x
BYTE2	x	x
BYTE3	x	OR x
BYTE4	x	x
BYTE5	.	.
BYTE6	x	0
BYTE7	Audio Status	=1=on
BYTE8	High Alarm Status	=1=on
BYTE9	Low Alarm Status	=1=on
BYTE10	Over Range Status	=1=on
BYTE11	Monitor Status	=1=on
BYTE12	Error Code	
BYTE13	Carriage Return (ODH)	
BYTE14	Line Feed (OAH)	

## 9-Pin Remote Data Connector (female sockets)

The 9-pin connector provides output signals from the instrument and input voltage to the instrument. The pin assignments are:

pin1-	+BATTERY
pin2-	GND IN
pin3-	FAIL_L
pin4-	RS232 DUMP
pin5-	ANALOG OUT
pin6-	CHASSIS GND
pin7-	HIGH ALARM_L
pin8-	EXT RESET_L
pin9-	+5VDC OUT

The FAIL and HIGH ALARM digital signal outputs are open drain 2N7002 outputs, able to sink about 50 mA each.

## 9-Pin Relays Connector (male pins)

The 9-pin relay connector provides a Form C (common, normally open, and normally closed) contact for the three fail-safe relays of LOW ALARM (alert), HIGH ALARM, and FAIL.

The pin assignments are (shown energized):

pin1-	FailNO
pin2-	FailNC
pin3-	AlertCOM
pin4-	AlarmNO
pin5-	AlarmCOM
pin6-	FailCOM
pin7-	AlertNO
pin8-	AlertNC
pin9-	AlarmNC

## Typical Internal Detector Setups

### **Model 375/2**

Typical response and set points for the model 375 with internal energy-compensated LND 71210 GM detector is as follows:

Operating Voltage: 550 Vdc  
 Threshold: 100 mVdc  
 Calibration Constant: 1000 cpm/mR/hr  
 Dead Time Correction: 30  $\mu$ sec-150  $\mu$ sec  
 Linear Range with DTC: 0.1 mR/hr - 1 R/hr

Typical Checkpoints:

1 mR/hr	
2 mR/hr	* set calibration constant
8 mR/hr	
20 mR/hr	
80 mR/hr	
200 mR/hr	* set dead time correction
800 mR/hr	
1000 mR/hr	

**Model 375/4**

Typical response and set points for the model 375 with internal energy-compensated LND 71412 GM detector is as follows:

Operating Voltage: 550 Vdc  
Threshold: 100 mVdc  
Calibration Constant: 100 cpm/mR/hr  
Dead Time Correction: 30  $\mu$ sec-150  $\mu$ sec  
Linear Range with DTC: 1 mR/hr - 8 R/hr

## Typical Checkpoints:

2 mR/hr  
8 mR/hr  
20 mR/hr \* set calibration constant  
80 mR/hr  
200 mR/hr  
800 mR/hr  
2,000 mR/hr  
8,000 mR/hr \* set dead time correction

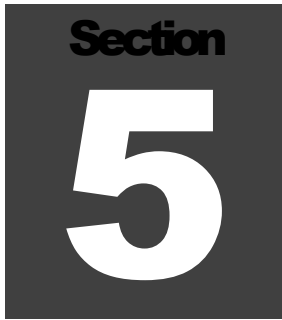

# Section 5

## Common Options and Modifications

---

### Relay Options

#### ***Internal Circuit-Board-Mounted Relays***

A 9-pin connector with male pins provides connection to three fail-safe form C relays, activated by the LOW ALARM (alert), HIGH ALARM, and instrument FAIL. These contacts are potential-free (non-powered), but can handle 125 Vac at 0.3 A or 30 Vdc at 1 A.

For additional flexibility, additional relay options are available at extra cost:

#### **Form C Relay (3 pin connector added) PN4558-036:**

This option allows the user to access the fail-safe form C contacts (normally open, normally closed, and common), which activate upon HIGH ALARM. This is achieved by using an additional 3-pin connector with male pins, located at the bottom of the instrument, wired in parallel with the 9 pin D male pin connector. These contacts are potential-free (non-powered), but can handle 125 Vac at 0.3 A or 30 Vdc at 1 A.

#### **RL1 Relay**

The added 3-pin connector has the following connections (shown energized):

Pin 1- normally open (NO) (ORG)

Pin 2- common (BRN)

Pin 3- normally closed (NC) (RED)

**External Mains (120 or 240 VAC) Alarm Relay Out (using 3 pin connector) PN4558-038:**

Allows the use of the 9-pin D female connector for RS-232 or remote use and does not interfere with the internal form C relays.

This option includes a small enclosure connected to the Model 375 via a short cable, that accepts a standard mains power cord (conduit option is 4558-038-1). In an ALARM condition, the mains voltage is relayed to a set of terminals. Only a licensed electrician should install this option.

Figure 1. Mains Relay Box Back Panel.

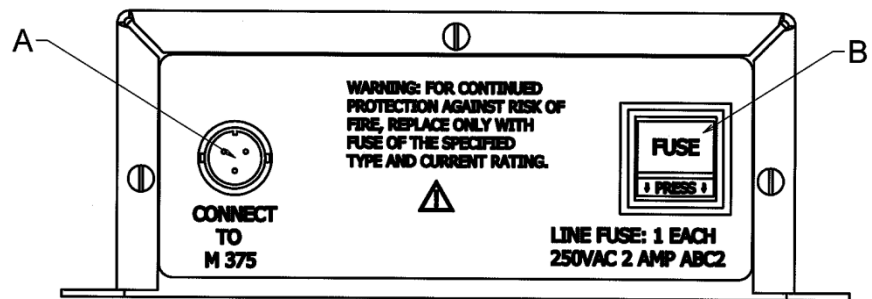

See below for description of noted parts in drawing above.

**A** – connector for cable (Part # 8303-879) that connects the mains relay box to the Model 375.

**B** – Use fuse that is noted in drawing above.

Figure 2. Mains Relay Box Front Panel.

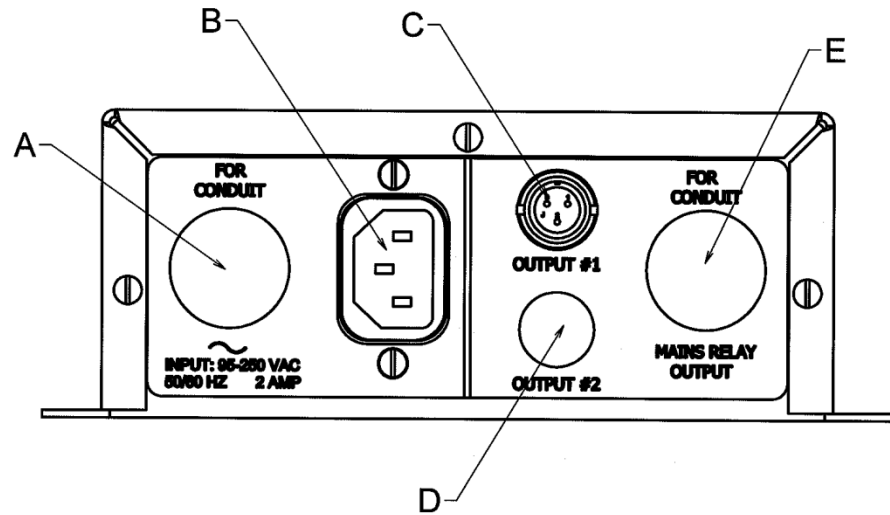

*See below for description of noted parts in drawing above.*

**A** – conduit connector to the box if necessary.

**B** – AC receptacle (removed if using conduit).

**C** – mains relay output 3-pin connectors.

**D** – optional extra output.

**E** – relay output for conduit if necessary.



Figure 3. Mains Relay Box Inside View.

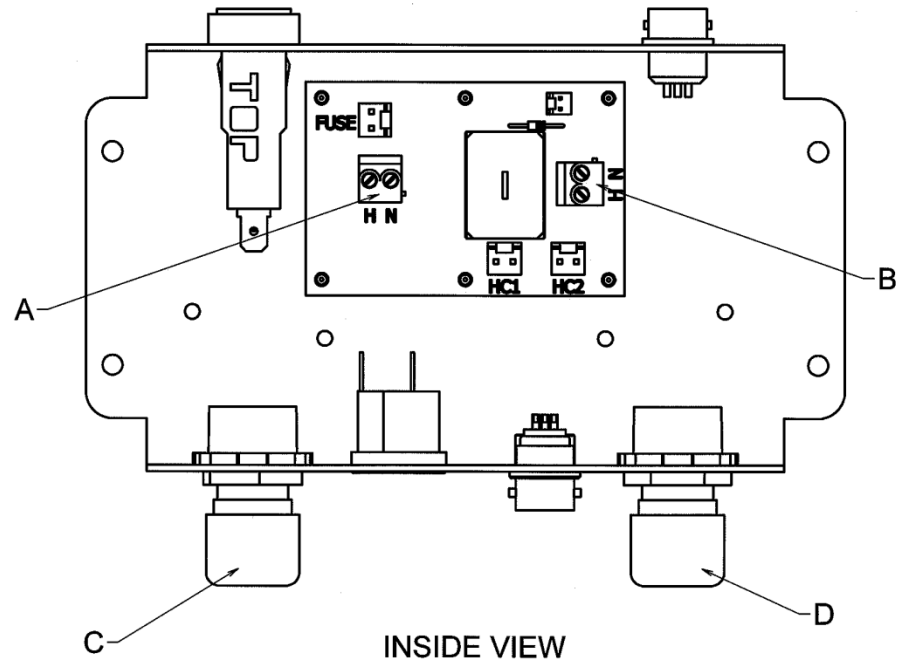

*See below for description of noted parts in drawing above.*

**A** – 110/220 Vac conduit AC input. “H” = hot and “N” = neutral. For 220 Vac, H = L1 and N = L2.

**B** – relay output. “H” = hot and “N” = neutral. For 220 Vac, H = L1 and N = L2.

**C** – optional conduit connector input.

**D** – optional relay output for conduit.

Strobe lights and/or horns are also available through Ludlum Measurements.

## Ethernet Interface Option

A 10-BaseT Ethernet interface may be added internally for network reporting, using Ludlum software:

- 4558-098 LMI “Ethernet” Hardware Interface
- 4558-105 LMI “Webpage” Hardware Interface

Either the Ethernet software (1370-055) or the Webpage software (1370-077) must be purchased separately (site-licensed).

## Time and Date Stamp Option

### Description:

When an alarm or failure occurs, the Model 375 will print the current reading, date, time, and either ALARM or FAIL to the RS-232 port. The Model 375 will print once every 30 seconds as long as the alarm or fail condition is present.

### Setup:

You will need the following: a Model 375 instrument, a CBM-910 40-column printer, and a cable (8558-142).

The printer should be configured at 2400 bps (baud), no parity, 8 data bits, 1 stop bit, and no handshaking. See printer manual for proper setup instructions.

### Setting the date and time:

Check the month and day (MMDD) by pressing the LOW ALARM and HIGH ALARM buttons simultaneously. The month and day will be displayed as long as those buttons are pressed. The month and day can be set from 0101 to 1231.

Check the year (YYYY) by pressing the LOW ALARM and CAL CONST buttons simultaneously. The year will be displayed as long as those buttons are pressed. The year can be adjusted from 0000 to 9999.

Check the hours and minutes (HHMM) by pressing the LOW ALARM and DEAD TIME buttons simultaneously. The hours and minutes will be displayed as long as those buttons are pressed. The hours and minutes can be adjusted from 0000 to 2359.

**RS-232 Data Format:**

The data will be sent to the RS-232 port as:

Byte 1	0	x	Byte 18	Space (20H)
Byte 2	x	x	Byte 19	H
Byte 3	x	OR x	Byte 20	H
Byte 4	x	x	Byte 21	:
Byte 5	.	.	Byte 22	M
Byte 6	x	0	Byte 23	M
Byte 7	Space (20H)		Byte 24	:
Byte 8	Space (20H)		Byte 25	S
Byte 9	Space (20H)		Byte 26	S
Byte 10	M		Byte 27	Space (20H)
Byte 11	M		Byte 28	A Space
Byte 12	/		Byte 29	L F
Byte 13	D		Byte 30	A OR A
Byte 14	D		Byte 31	R I
Byte 15	/		Byte 32	M L
Byte 16	Y		Byte 33	Carriage Return (0DH)
Byte 17	Y		Byte 34	Line Feed (0AH)

**Example Output:**

```
0642.1 04/21/95 16:56:24 ALARM
0000.0 04/21/95 08:32:16 FAIL
```

**Printer DIP Switch Settings****Citizen Dot Matrix Printer Model CBM-910 Type II**

Please refer to page 32 of the printer user's manual for the location of the DIP Switches. Switches 2, 3, and 6 should be in the ON position (toward the back of the printer). Switches 1, 4, 5, 7, and 8 should be in the OFF position (toward the front of the printer). (In the figure below, the white on the switch indicates the direction the switch is set. ON is at the top.)

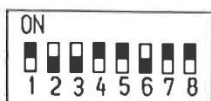

## Sigma Alarm Modification Option

With this option, special firmware allows the Model 375 to have a sigma-based alarm point in addition to a regular fixed alarm point. This sigma-based alarm point allows the user to have a floating alarm point that will stay at “x” sigma above the radiation background. As the background changes, the sigma alarm also changes. The sigma alarm, when activated, activates a rapid beeping and activates the HIGH ALARM indicator on the front panel of the Model 375.

To set the sigma alarm, one first needs to consult a probability table showing one-sided sigma values. If the sigma alarm (read or set by the LOW ALARM button) is set to 3.0, that setting statistically means that 99.87% of normal background readings would be less than the alarm point. To look at the false alarm rate, it means that 0.13% or 1 out of 769 comparisons would result in a false alarm. Since comparisons are made every second, a setting of 3.0 will result in a false alarm about every 13 minutes. Similarly, a setting of 5.0 would result in a false alarm every 38 days. To actually calculate the sigma alarm point, it is necessary first to determine the background radiation level in cps (counts per second). The sigma alarm point is then  $BKGND + (x \text{ sigma} \times \text{square root of BKGND})$ .

The HIGH ALARM has *not* been changed; it is still a fixed alarm point and will be activated when the radiation level exceeds that setpoint. This feature allows the sigma alarm to trigger quickly if a small amount of radiation is present and allows the fixed alarm to warn that the background radiation is too high. Since the sigma alarm is allowed to rise if the background rises, the HIGH ALARM is necessary to have an absolute value or ceiling for the radiation level. The time constant for the background radiation level and the displayed radiation reading is 20 seconds. The sigma alarm is not activated until 60 seconds after the Model 375 is turned ON, in order to allow the Model 375 to accumulate a stable background radiation reading.

Two other changes were made to the Model 375. The first change was to deactivate the LOW ALARM indicator. Both the sigma-based alarm (set by the LOW ALARM button) and the fixed alarm (HIGH ALARM button) trigger the HIGH ALARM indicator. The second change was to lower the detector loss-of-count time frame to 15 seconds. This change means that the DET FAIL indicator is activated if no pulses are received from the radiation detectors in 15 seconds. Since the sigma alarm is most useful for scintillation detectors that have several hundred pulses per minute, this change allows a faster determination of detector failure.

## 4 to 20 mA Isolated Output Driver Option

### 4 to 20 mA Driver (Isolated) Modification Kit Part Number 4558-104

This circuit may be added to replace the Model 375 analog output, providing an isolated 4 to 20 mA output capability.

The circuit has an internal loop supply, generating +12 Vdc from the RAWDC of the Model 375. It is designed for a 2-wire configuration, with one conductor carrying the 4-20 mA current signal and the second conductor providing a return (isolated loop ground). See Wiring Diagram, Figure 4 (below).

Figure 4: Wiring Diagram.

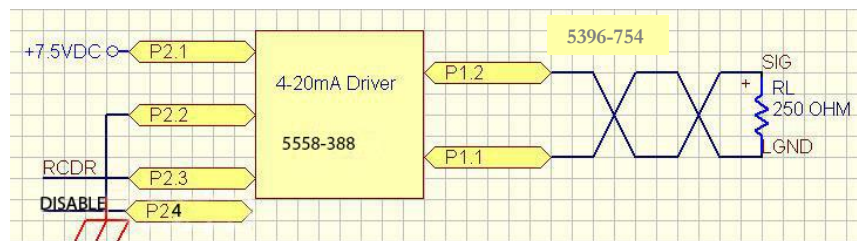

Decade	“Base” Display	mA Value
0	0.1	4 mA
1	1	7.2 mA
2	10	10.4 mA
3	100	13.6 mA
4	1000	16.8 mA
5	10,000	20 mA

For Series One:

Decade	“Base” Display	mA Value
0	0.01	4 mA
1	0.10	7.2 mA
2	1.00	10.4 mA
3	10.00	13.6 mA
4	100	16.8 mA
5	1000	20 mA

$$\text{mA value} = 4 \text{ mA} + (3.2 \text{ mA} * \text{Decade}) + 3.2 \log \left( \frac{\text{display reading}}{\text{base}} \right)$$

$$\text{Display reading} = 10^{\frac{\text{mA value} - 4 - (3.2 * \text{decade})}{3.2}} * \text{base}$$

**Note:** For the Model 375 Series One (that displays values to two decimal places), the 4-20 mA output starts a decade lower, from 0.01 to 0.1 units, with the highest decade being 100 to 1000 units. The full-scale output of 20 mA can be adjusted for a reading of 1000 units. The highest displayed range of 1000 to 10,000 units then has a constant 20 mA output.

## ***SPECIFICATIONS***

**Power Required:** 7.5 Vdc at 100 mA; minimum  $V_{in} = 5.5 \text{ V}$  and maximum  $V_{in} = 15 \text{ V}$  (connected internally)

**Terminating Resistor:** 250 ohm

**Model 375 4 to 20 mA Isolated Output Connections (3-pin Hirose connector)**

Pin 1 is black (negative).  
Pin 2 is white (positive).

**Internal Board Header Pinout**

- P1-1) Loop GND (Isolated)
- P1-2) 4-20 current output (Isolated)
- P2-1) +7.5 Vdc , RAWDC from main circuit board number 5396-160  
(May range from +5.5 to 15 Vdc)
- P2-2) GND
- P2-3) RCDR

**CALIBRATION**

Apply 0 counts or RESET the Model 375.

Check for a voltage of 1.00 V  $\pm 5\%$  across Rterm, typically a 250 ohm ( $V = 0.004 \times R_{term}$ ) terminating resistor. The resistor should be placed between Pin 5 (the 4-20 mA output) and Pin 6 (Loop ground).

**Note:**

Loop ground is isolated from instrument ground.

Now apply a full-scale meter reading to the analog input, or move the CAL dipswitch to the right.

**Note:**

Instrument ground is not the same as loop ground.

Adjust the SPAN trimmer, R5, until the voltage across the 250-ohm terminating resistor is 5 V  $\pm 5\%$  ( $V = .020 \times R_{tem}$ ).

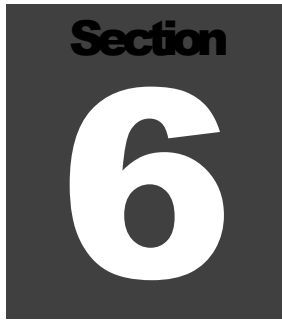
A dark gray square containing the word "Section" in a small, white, sans-serif font at the top, and a large, white, bold number "6" in the center.

## Safety Considerations

---

### Environmental Conditions for Normal Use

Indoor use only

No maximum altitude

Temperature range of -15 to 50 °C (5 to 122 °F); may be certified for operation from -40 °C (-40 °F)

Maximum relative humidity of less than 95% (non-condensing)

Mains supply voltage range of 100-240 Vac ,  
50/60Hz single phase (less than 100 mA typical, 1 amp max) to wall-mounted DC adapter supplying 9-12 Vdc

Maximum transient voltage of 1500 Vac

Installation Category II (Overvoltage Category as defined by IEC 1010-1)

Pollution Degree 2 (as defined by IEC 664)

### Cleaning Instructions and Precautions

The Model 375 may be cleaned externally with bleach wipes or with a damp cloth, using water, Lysol or alcohol as a wetting agent. Do not immerse the instrument in any liquid. Observe the following precautions when cleaning:

1. Turn the instrument OFF and disconnect the instrument power cord.
2. Allow the instrument to sit for one minute before cleaning.



## Warning Markings and Symbols

### Caution!

The operator or responsible body is cautioned that the protection provided by the equipment may be impaired if the equipment is used in a manner not specified by Ludlum Measurements, Inc.

### The Model 375 is marked with the following symbols:



**CAUTION, RISK OF ELECTRIC SHOCK** (per ISO 3864, No. B.3.6) – designates a terminal (connector) that allows connection to a voltage exceeding 1 kV. Contact with the subject connector while the instrument is on or shortly after turning off may result in electric shock. This symbol appears on the side panel (Applicable for Models with an external detector).



**DIRECT CURRENT (DC)** (IEC 417, No. 5032) - designates an input receptacle that accommodates a power cord intended for connection to DC voltages. This symbol appears on the side panel.



**PROTECTIVE CONDUCTOR TERMINAL** (per IEC 417, No. 5019) – designates the central grounding point for the safety ground. This symbol is visible inside the chassis.



**CAUTION** (per ISO 3864, No. B.3.1) – designates hazardous live voltage and risk of electric shock. During normal use, internal components are hazardous live. This instrument must be isolated or disconnected from the hazardous live voltage before accessing the internal components. This symbol appears on the side panel. **Note the following precautions:**

### Caution!

Do not touch the circuit board in the calibration window due to possible electric shock.

### Caution!

Verify instrument voltage input rating before connecting to a power converter. If the wrong power converter is used, the instrument and/or power converter could be damaged.

**Warning!**

The operator is strongly cautioned to take the following precautions to avoid contact with internal hazardous live parts that are accessible using a tool:

1. Turn the instrument power OFF and disconnect the power cord.
2. Allow the instrument to sit for one minute before accessing internal components.



The “**crossed-out wheellie bin**” symbol notifies the consumer that the product is not to be mixed with unsorted municipal waste when discarding; each material must be separated. See section 8, “Recycling” for further information. Also displayed on the side panel.



The “CE” mark is used to identify this instrument as being acceptable for use within the European Union.

## Electrical Safety Precautions

**Warning!**

Observe the following instructions to avoid a potentially hazardous situation which, if mishandled, could result in death or serious personal injury, as well as property damage.

- Do not expose the unit to rain or an environment where it may be splashed by water or other liquids, as doing so may result in fire or electric shock.
- Use the unit only with the voltage specified on the unit. Using a voltage higher than that which is specified may result in fire or electric shock.
- Do not cut, kink, or otherwise damage nor modify the power supply cord. IN addition, avoid using the power cord in close proximity to heaters, and never place heavy objects – including the unit itself – on the power cord, as doing so may result in fire or electric shock.
- Avoid installing or mounting the unit or its power supply in unstable conditions, such as a rickety table or a slanted surface. Doing so may

result in the unit falling down and causing personal injury and/or property damage.

## Detector Connector

### Warning!

Potential electrical shock hazard: do not touch the center pin of the detector connector unless the unit has turned off and power has been removed for at least one minute.

## Battery Replacement

### Warning!

Only certified technicians or calibration personnel should replace battery.

### Note:

Ludlum Measurements, Inc. recommends replacing batteries every four years.

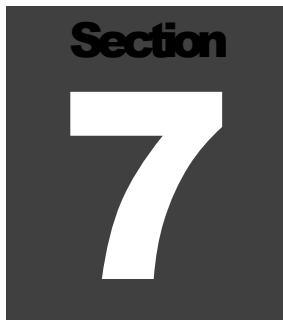
A dark gray square containing the word "Section" in a bold, white, sans-serif font at the top, and a large, white, bold number "7" in the center.

## Calibration

---

### High Voltage

The high voltage is adjustable from 450-2500 Vdc using the HV potentiometer located under the calibration cover. The high voltage required will depend on the type of detector used. Internal GM detectors usually require 550 Vdc. Ensure that the high voltage is checked only with a high-impedance ( $\geq 1000$  megohm) voltmeter. A high-voltage checkpoint is located next to the HV potentiometer.

**Warning!**

Do not touch the circuit board in the calibration window due to potential for electric shock.

### Calibration Parameters

The calibration parameters, LOW ALARM, HIGH ALARM, CAL CONST, and DEAD TIME can only be changed while in calibration mode. Switch the top dipswitch CAL MODE to the right to switch into calibration mode. Changing any parameter is done by holding down the parameter key and pressing the up or down arrow buttons. Any parameter can be set in the range of 0.1 to 9999\*. If a parameter is changed, the instrument will beep to confirm the saving of the parameter, and then return to displaying the current radiation level.

The calibration constant (CAL CONST) is set when the detector is exposed to a "low" radiation field. A "low" radiation field in this case is defined as a field where dead time losses do not exceed 5%. The calibration constant is usually given for a certain detector. A Ludlum Model 133-4 detector, for example, has a calibration constant of approximately 100 cpm/mR/hr. Once the calibration constant is set and checked at a low radiation field, the dead time correction can be set.

The dead time correction (DEAD TIME) is set when the detector is exposed to a "high" radiation field. A "high" radiation field in this case is defined as a field where dead time losses exceed 30%. The dead time correction will elevate the ratemeter reading to account for counts arriving at the detector during the detector's dead time. GM tubes typically have long dead times from 50-150 microseconds. Neutron and scintillation detectors generally have short dead times of 1-5 microseconds.

**Note:**

Once parameters are set, it is important to remember to switch the CAL MODE switch back to the left. This action protects the parameters from inadvertent changes.

## Analog Output

The analog output is a five-decade logarithmic voltage-out. The maximum voltage-out while under primary power is 6 volts. The maximum voltage-out while under battery backup power is 4.5 volts. The five decades are:

0.1 <units> - 1.0 <units>\*  
1 <units> - 10 <units>\*  
10 <units> - 100 <units>\*  
100 <units> - 1000 <units>\*  
1000 <units> - 10000 <units>\*

When the CAL MODE dip switch is switched to the right, the analog output goes to full scale. The analog output goes to full scale during a DET FAIL condition.

**Note:** For the Model 375 Series One (that displays values to two decimal places), the analog output starts a decade lower, from 0.01 to 0.1 units, with the highest decade being 100 to 1000 units. The highest displayed range of 1000 to 10,000 units then has a constant full-scale output.

## Discriminator

The DISC potentiometer located under the calibration cover is used to set the threshold for pulses coming from the detector. The desired pulse threshold depends on the type of detector used. It is adjustable from 2.0 mVdc to 100 mVdc.

## **Battery Charge**

The potentiometer labeled BAT, located under the calibration cover, is used to set the backup battery trickle-charge voltage. This is typically set to 6.9 Vdc with the battery disconnected.

**\* See note on page 2-3 regarding Model 375 Series One.**

**Section**  
**8**

**Recycling**

Ludlum Measurements, Inc. supports the recycling of the electronics products it produces for the purpose of protecting the environment and to comply with all regional, national, and international agencies that promote economically and environmentally sustainable recycling systems. To this end, Ludlum Measurements, Inc. strives to supply the consumer of its goods with information regarding reuse and recycling of the many different types of materials used in its products. With many different agencies – public and private – involved in this pursuit it becomes evident that a myriad of methods can be used in the process of recycling. Therefore, Ludlum Measurements, Inc. does not suggest one particular method over another, but simply desires to inform its consumers of the range of recyclable materials present in its products, so that the user will have flexibility in following all local and federal laws.

The following types of recyclable materials are present in Ludlum Measurements, Inc. electronics products, and should be recycled separately. The list is not all-inclusive, nor does it suggest that all materials are present in each piece of equipment:

- |                |          |                              |
|----------------|----------|------------------------------|
| Batteries      | Glass    | Aluminum and Stainless Steel |
| Circuit Boards | Plastics | Liquid Crystal Display (LCD) |

Ludlum Measurements, Inc. products, which have been placed on the market after August 13, 2005, have been labeled with a symbol recognized internationally as the “crossed-out wheelie bin.” This notifies the consumer that the product is not to be mixed with unsorted municipal waste when discarding; each material must be separated. The symbol will be placed near the AC receptacle, except for portable equipment where it will be placed on the battery lid.

The symbol appears as such:



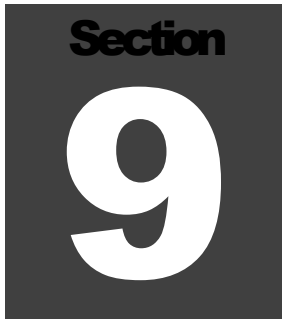

## Parts List

---

	Reference	Description	Part Number
<b>Model 375 Digital Wall-Mount Area Monitor without Detector</b>	UNIT	Completely Assembled Model 375	48-2230
<b>Model 375/1 Digital Wall-Mount Area Monitor</b>	UNIT	Completely Assembled Model 375/1	48-3831
<b>Model 375/2 Digital Wall-Mount Area Monitor</b>	UNIT	Completely Assembled Model 375/2	48-2410
<b>Model 375/4 Digital Wall-Mount Area Monitor</b>	UNIT	Completely Assembled Model 375/4	48-2411
<b>Model 375 Series One without Detector</b>	UNIT	Completely Assembled Model 375 Series One	48-2676
<b>Model 375/2 Series One</b>	UNIT	Completely Assembled Model 375/2 Series One	48-2931
<b>Model 375/4 Series One</b>	UNIT	Completely Assembled Model 375/4 Series One	48-3007
<b>Main Board, Drawing 558 x 545</b>	BOARD	Completely Assembled Main Circuit Board (common to all)	5558-545
CRYSTAL	Y211	6.144 MHZ	01-5262
CAPACITORS	C1-C2	100µF, 16V	04-5794
	C4	100µF, 16V	04-5794
	C5-C6	10µF, 25V	04-5728
	C7	100µF, 16V	04-5794
	C8	10µF, 25V	04-5728



	Reference	Description	Part Number
	C9-C11	100 $\mu$ F, 16V	04-5794
	C12-C21	0.1 $\mu$ F, 500V	04-5696
	C22-C23	0.01 $\mu$ F, 3kV	04-5762
	C24-C33	0.1 $\mu$ F, 500V	04-5696
	C35	100pF, 100V	04-5743
	C36	10 $\mu$ F, 25V	04-5728
	C37	100pF, 100V	04-5743
	C38	100 $\mu$ F, 16V	04-5794
	C39-C40	10 $\mu$ F, 25V	04-5728
	C41-C43	10 $\mu$ F, 25V	04-5655
	C44-C53	0.1 $\mu$ F, 25V	04-5744
	C54	10 $\mu$ F, 25V	04-5655
	C55-C56	0.1 $\mu$ F, 25V	04-5744
	C57	4.7pF, 200V	04-5787
	C201	10 $\mu$ F, 25V	04-5655
	C211	27pF, 100V	04-5658
	C221	100 $\mu$ F, 16V	04-5794
	C222	27pF, 100V	04-5658
	C301-C303	10 $\mu$ F, 25V	04-5655
	C401	100 $\mu$ F, 16V	04-5794
	C422-C432	47pf, 100V	04-5660
	C441-C442	100 $\mu$ F, 16V	04-5794
	C531	0.047 $\mu$ F, 16V	04-5729
	C541-542	10 $\mu$ F, 25V	04-5655
	C543	6800 $\mu$ F, 25V	04-6079
	C611	10 $\mu$ F, 25V	04-5655
	C621	0.01 $\mu$ F, 50V	04-5664
	C711-C712	10 $\mu$ F, 25V	04-5655
	C721	10 $\mu$ F, 25V	04-5655
	C722	0.001 $\mu$ F, 100V	04-5659
	C731	100pF, 3kV	04-5735
TRANSISTORS	Q1-Q3	2N7002L	05-5840
	Q4	CMXT3904TRLF	05-5888
	Q5	CMXT-3906TRLF	05-5890
	Q6	CMXT3904TRLF	05-5888
	Q7	2N7002L	05-5840
	Q151-Q154	2N7002L	05-5840
	Q321-Q322	2N7002L	05-5840
	Q331	MJD200RLG	05-5844

	Reference	Description	Part Number
	Q431	2N7002L	05-5840
VOLTAGE REGULATOR	VR1	CMSH1-40M	07-6411
	VR341	LT1129CQ-5	06-6372
INTEGRATED CIRCUITS	U2	MAX985EUK+T	06-6459
	U3	LT1304CS8	06-6394
	U4	ICL7660SCBAZ	06-6437
	U5	TCM810LVNB713	06-6424
	U31	SA08-11EWA	07-6389
	U32	KB-2785YW	07-6371
	U41	KB-2685EW	07-6400
	U111	ICM7218CIQI-LFT	06-6311
	U131	SA08-11EWA	07-6389
	U201	MAX220ESE+T	06-6329
	U231	SA08-11EWA	07-6389
	U232	KB-2785YW	07-6371
	U233	SA08-11EWA	07-6389
	U241	KB-2685EW	07-6400
	U251	TLC372IDR	06-6290
	U321	M24C02-WMN6TP	06-6299
	U331	ICL7663SCBAZA-T	06-6302
	U411	AT89C51RC2	06-6893
	U521	CD74HC4538M96	06-6297
	U531	OPA2343UA2K5	06-6582
	U611	MAX985EUK+T	06-6459
	U711	LM285DR-1-2	05-5845
DIODES	CR1	CMSH1-40M	07-6411
	CR2	P0640SCMCLRP	21-9028
	CR3	MMBD914LT1G	07-6353
	CR12	MMBD914LT1G	07-6353
	CR15	CMSH1-40M	07-6411
	CR16	MMBD914LT1G	07-6353
	CR17-CR21	P0080SC	21-9004
	CR22-CR31	CMPD2005SLF	07-6468
	CR32	CMSH1-40M	07-6411
	CR33-CR34	CMPD2005SLF	07-6468
	CR35	CMSH1-40M	07-6411
	CR36	P0080SC	21-9004
	CR38	US1M-E3	07-6530
	CR341-CR342	CMSH1-40M	07-6411

	Reference	Description	Part Number
LED	DS11	KB-2550SGD	07-6370
SWITCHES	S001	ALERT POINT	08-6728
	S101	ALARM POINT	08-6728
	S201	CALIBRATION CONSTANT	08-6728
	S301	DEADTIME CORRECTION	08-6728
	S501	DOWN	08-6728
	S511	UP	08-6728
	S512	OPTION DIPSWITCH	08-6709
	SW1	POWER	08-6840
POTENTIOMETER	R13	1M, BAT CHG ADJ	09-6778
	R16	1M, HV ADJ	09-6778
	R523	1M, OVLD ADJ	09-6778
	R535	200K, THR ADJ	09-6949
	R537	5K, RCDR	09-6849
RESISTORS	R1-R4	301ohm, 1%, 250mW	12-7863
	R5-R6	1M, 1%, 250mW	12-7844
	R7	4.75M, 1%, 250mW	12-7995
	R8	500M, 2%, 3kV	12-7031
	R9	165K, 1%, 125mW	12-7877
	R10	500M, 2%, 3kV	12-7031
	R11	100ohm, 1%, 250mW	12-7840
	R12	301ohm, 1%, 250mW	12-7863
	R14	165K, 1%, 250mW	12-7877
	R15	1M, 1%, 250mW	12-7844
	R17	1ohm, 5%, 250mW	12-7205
	R18	82.5K, 1%, 250mW	12-7849
	R19-R22	2.2ohm, 5%, 250mW	12-7932
	R23	100K, 1%, 250mW	12-7834
	R24	1M, 1%, 250mW	12-7844
	R25	10ohm, 1%, 125mW	12-7836
	R26	100ohm, 1%, 100mW	12-7142
	R27	100K, 1%, 250mW	12-7834
	R28	0ohm, JUMPER 1206	12-7104
	R41	2.2ohm, 5%, 250mW	12-7932
	R42	60.4ohm, 1%, 250mW	12-7962
	R141	2.2ohm, 5%, 250mW	12-7932
	R142	60.4ohm, 1%, 250mW	12-7962
	R151-R152	100K, 1%, 250mW	12-7834
	R201	24.3K, 1%, 250mW	12-7867
	R241	2.21K, 1%, 250mW	12-7835

	Reference	Description	Part Number
	R251	10K, 1%, 250mW	12-7839
	R252	24.3K, 1%, 250mW	12-7867
	R253	82.5K, 1%, 250mW	12-7849
	R331	1K, 1%, 250mW	12-7832
	R332	165K, 1%, 250mW	12-7877
	R341	1ohm, 5%, 250mW	12-7205
	R421-R422	100K, 1%, 250mW	12-7834
	R431	1K, 1%, 250mW	12-7832
	R432	1M, 1%, 250mW	12-7844
	R531	10K, 1%, 250mW	12-7839
	R532	100K, 1%, 250mW	12-7834
	R533	10K, 1%, 250mW	12-7839
	R534	2.21K, 1%, 250mW	12-7835
	R611	47.5K, 1%, 250mW	12-7872
	R621	4.75K, 1%, 250mW	12-7858
	R622	10K, 1%, 250mW	12-7839
	R623	1K, 1%, 250mW	12-7832
	R631	47.5K, 1%, 250mW	12-7872
	R713-R714	10K, 1%, 250mW	12-7839
	R721	10K, 1%, 250mW	12-7839
	R722	165K, 1%, 250mW	12-7877
	R723	1K, 1%, 250mW	12-7832
	R724	4.75K, 1%, 250mW	12-7858
	R732-R733	100K, 1%, 250mW	12-7834
	R735	10K, 1%, 250mW	12-7839
RESISTOR NETWORK	RN411	1K	12-8291
CONNECTOR	P1	RAPC712	13-8445
	P2	640457-3 BAT	13-8165
	P4	9 PIN D CONN-747197-4	13-8364
	P6	747020-2 9 PIN D FEMALE	13-8555
	P7	640456-3 MTA 100X3 4-20mA	13-8081
	P8	640457-4 MTA 100X4RA SONALERT	13-8089
	P9	640456-3 MTA 100X3 4-20mA	13-8081
	P10	640457-2 MTAX2RA ALARM OUT	13-8147
	P11	640456-4 MTA 100X4 WHITE	13-8088

	Reference	Description	Part Number
INDUCTORS	L1	1Kohm	21-9008
	L3-L4	2700ohm	21-9009
	L8	2700ohm	21-9009
	L9	1Kohm	21-9008
	L411	220 $\mu$ HY	21-9678
RELAY	RL1-RL3	G6K-2FY DC5	22-9332
TRANSFORMER	T1	32377R	21-9925
MISCELLANEOUS	*	SOCKET 44P PLCC	06-6613
	S2	SHIELD-M4500 PREAMP	7436-142
	FID1-FID3	1mm	*
	W1	COAX, WIRE	*
	W3-W5	WIRE	*
	TP1-TP3	COAX, WIRE	*
	TP4	TEST POINT	*
<b>Wiring Diagram, Drawing 558 x 136</b> AUDIO	DS1	TXC-V86-515-Q WARNING DEVICE	218802
	FUSE	F1	RUEF110, 1.1A, 30V
BATTERY	B1	BATTERY-PS630	21-9705
<b>Internal Detectors</b>	*	Model 375/2 (only) DET ASSY.	4396-055
	*	Model 375/4 (only) DET ASSY.	4396-056

**Section**  
**10**

## **Drawings and Diagrams**

---

Main Circuit Board, Drawing 558 x 1 (5 sheets)

Main Circuit Board Component Layout Drawing 558 x 2A (2 sheets)

Wiring Diagram, Drawing 558 x 136

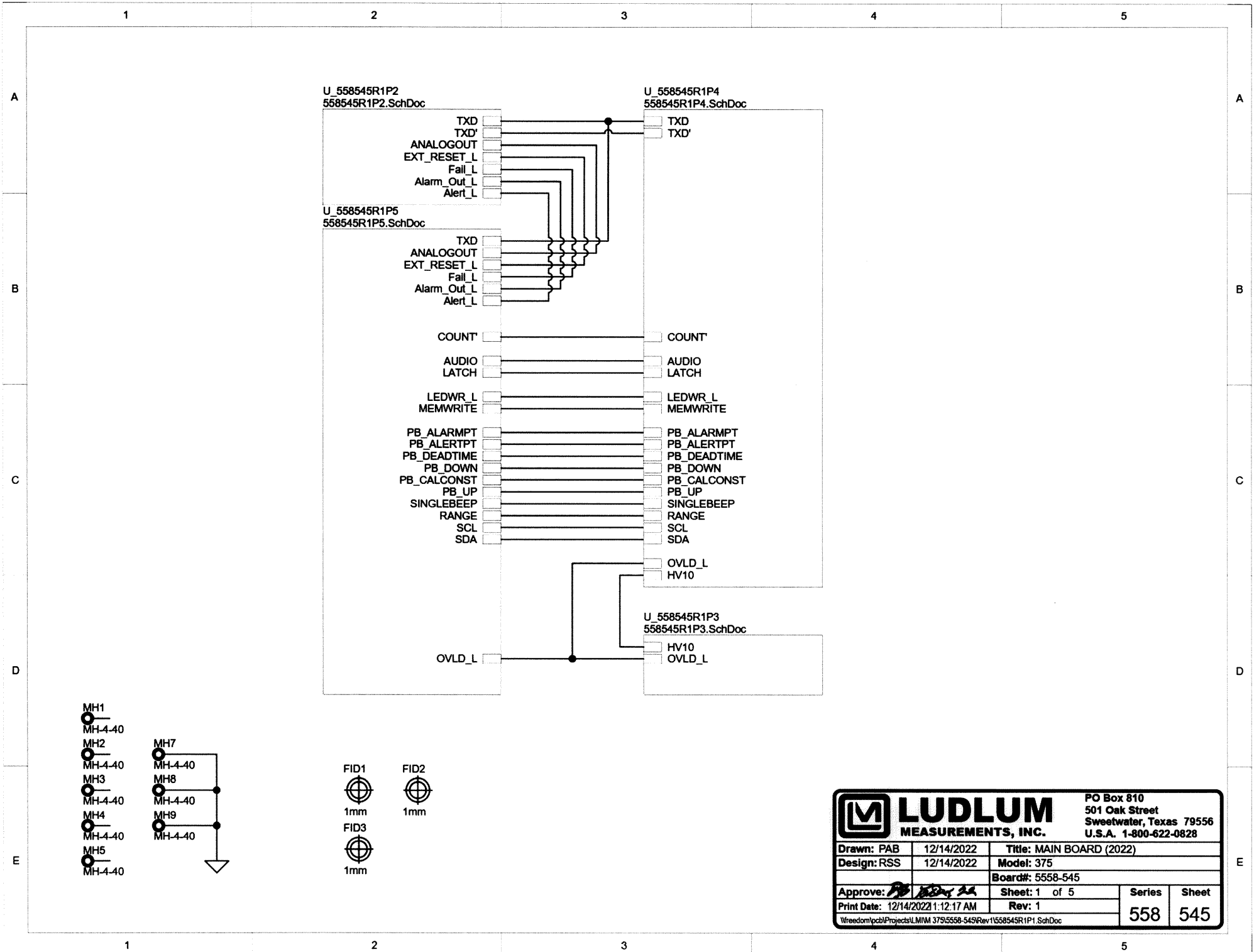

		<b>LUDLUM</b>		PO Box 810 501 Oak Street Sweetwater, Texas 79556 U.S.A. 1-800-622-0828	
Drawn: PAB	12/14/2022	Title: MAIN BOARD (2022)			
Design: RSS	12/14/2022	Model: 375			
		Board#: 5558-545			
Approve:		Sheet: 1 of 5		Series	Sheet
Print Date: 12/14/2022 1:12:17 AM		Rev: 1		558	545
\\freedom\pcb\Projects\LMM\375\5558-545\Rev1\558545R1P1.SchDoc					

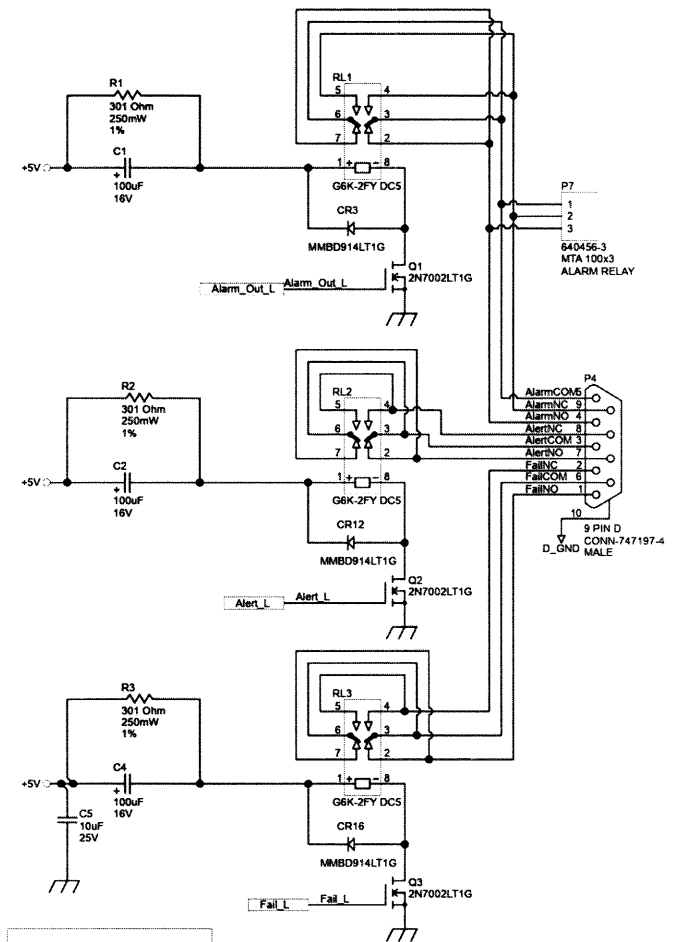
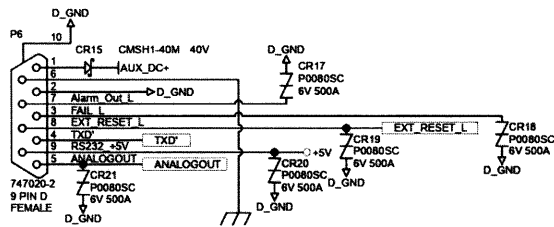
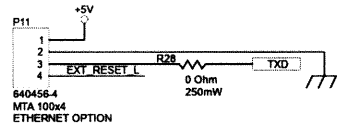
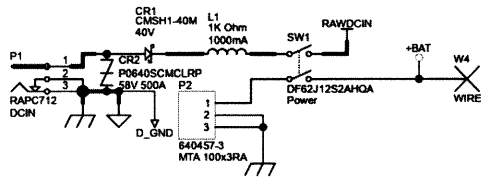

While relay symbols are shown non-energized, labels on 9 pin connector (P4) indicate normal energized condition

<b>LUDLUM</b> MEASUREMENTS, INC.		PO Box 810 581 Oak Street Sweetwater, Texas 79556 U.S.A. 1-800-622-0828	
Drawn: PAB	12/14/2022	Title: MAIN BOARD (2022)	
Design: RSS	12/14/2022	Model: 375	
		Board#: 558-545	
Approved: <i>[Signature]</i>		Sheet: 2 of 5	Series
Print Date: 12/14/2022 1:12:18 AM		Rev: 1	Sheet
www.ludlum.com			558 545



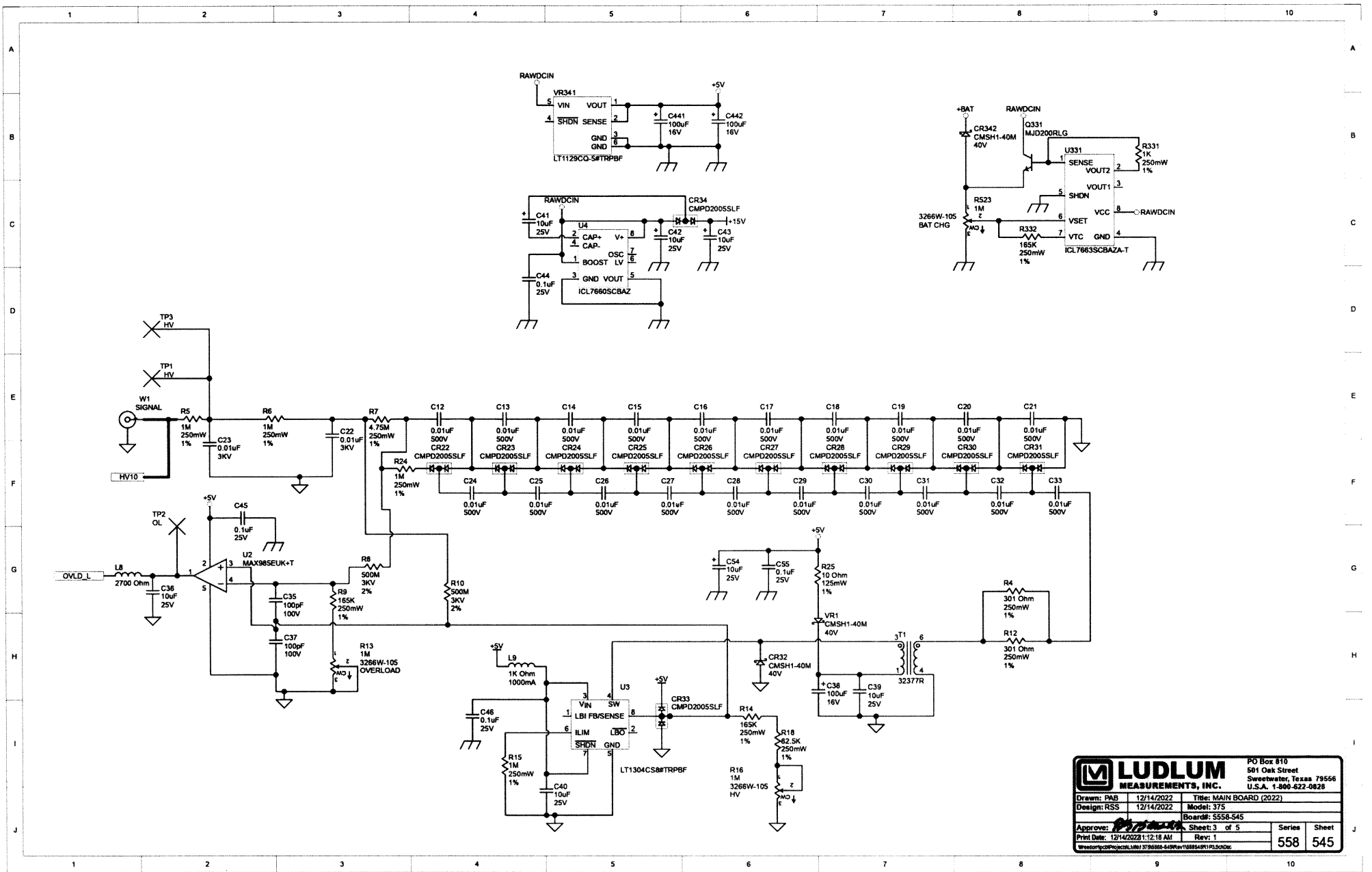

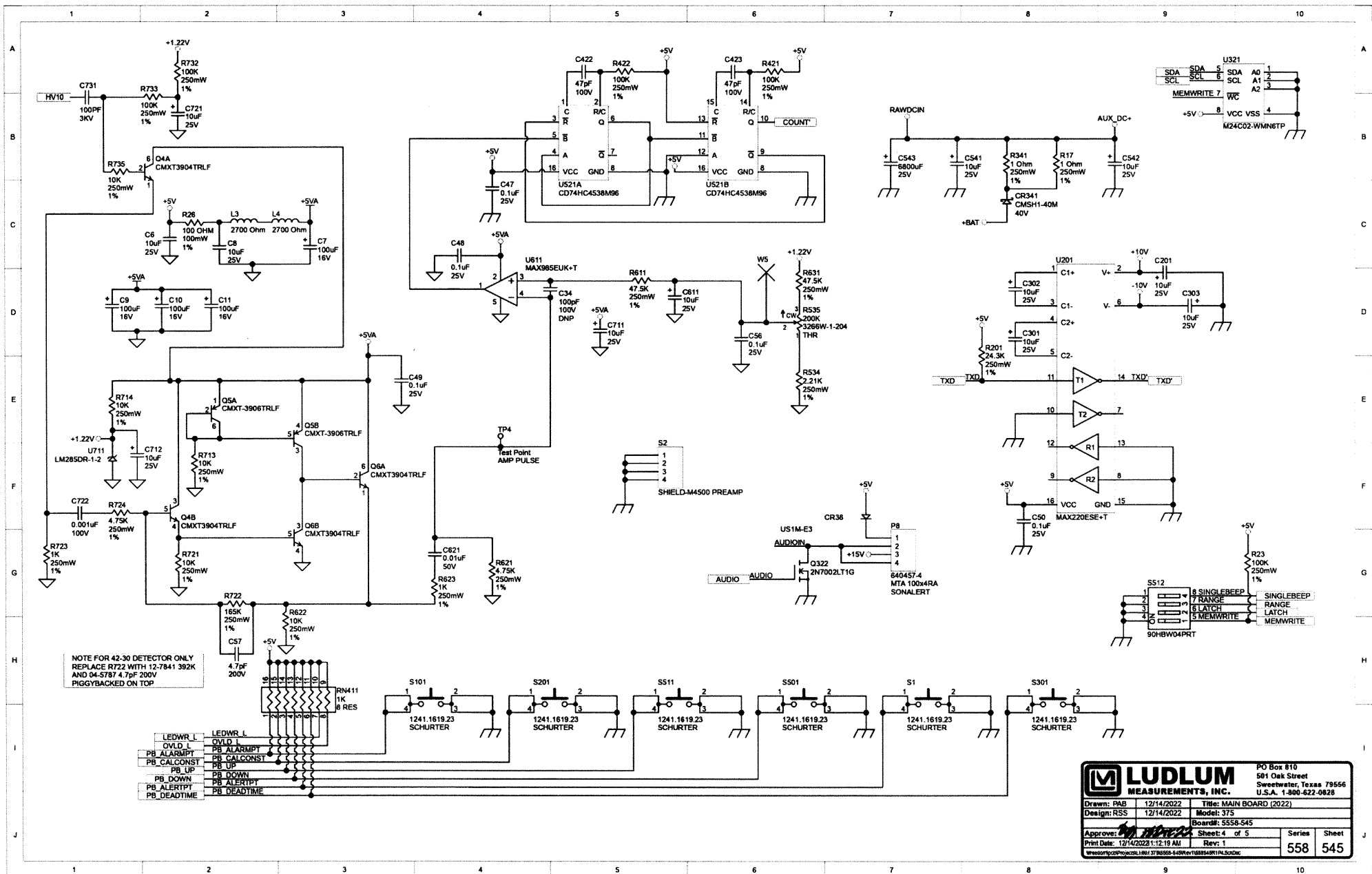

		PO Box 810 501 Oak Street Sweetwater, Texas 79556 U.S.A. 1-900-622-0828	
		Drawn: DAB Design: RSS	12/14/2022 12/14/2022
Approve:	Sheet: 3 of 5	Series: 558	Sheet: 545
Print Date: 12/14/2022 1:12:16 AM		Rev: 1	Model: 375
File Path: \\server\proj\proj\main\5736368-648R\N5558-545\PL5.DOC			

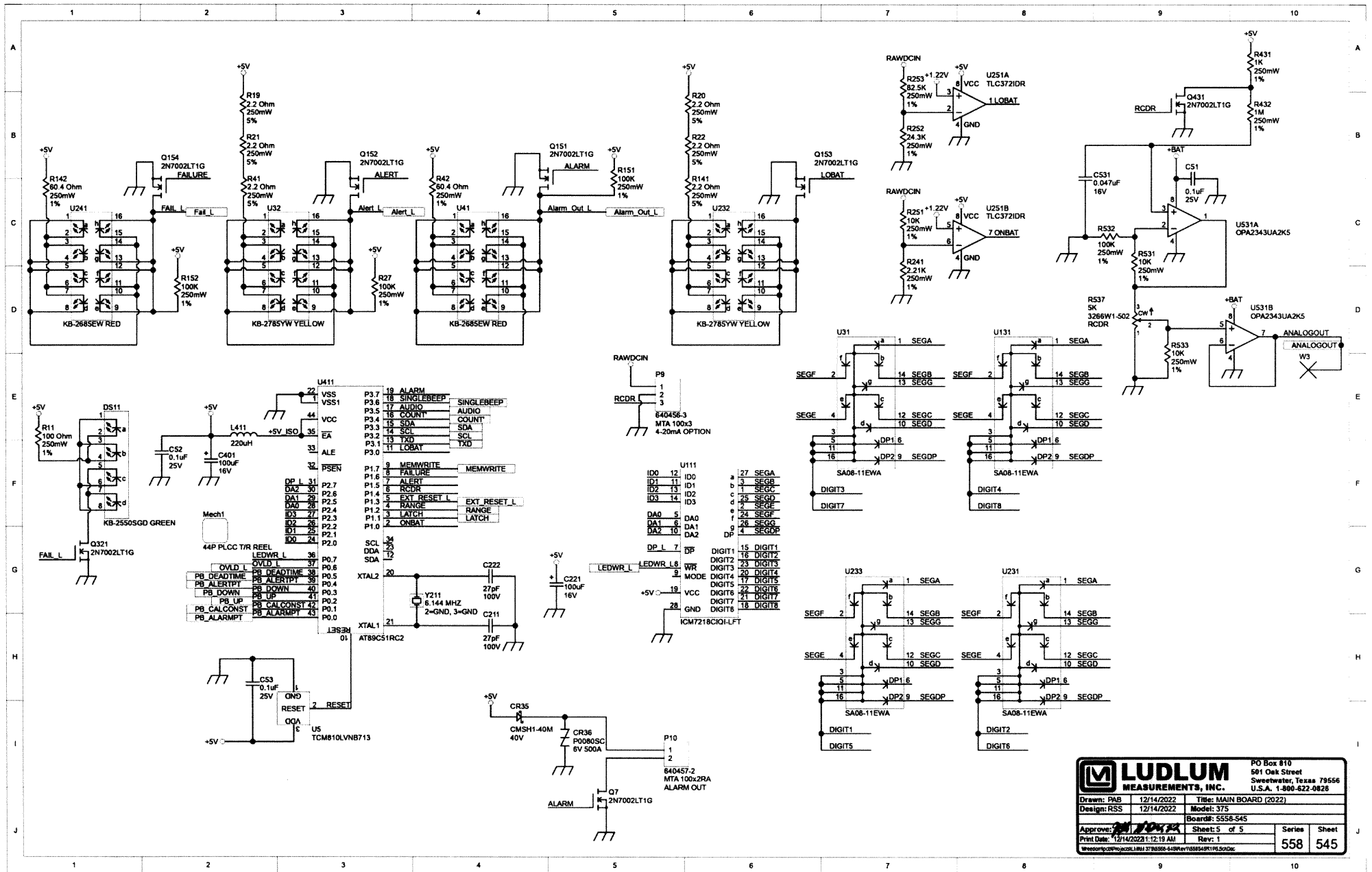



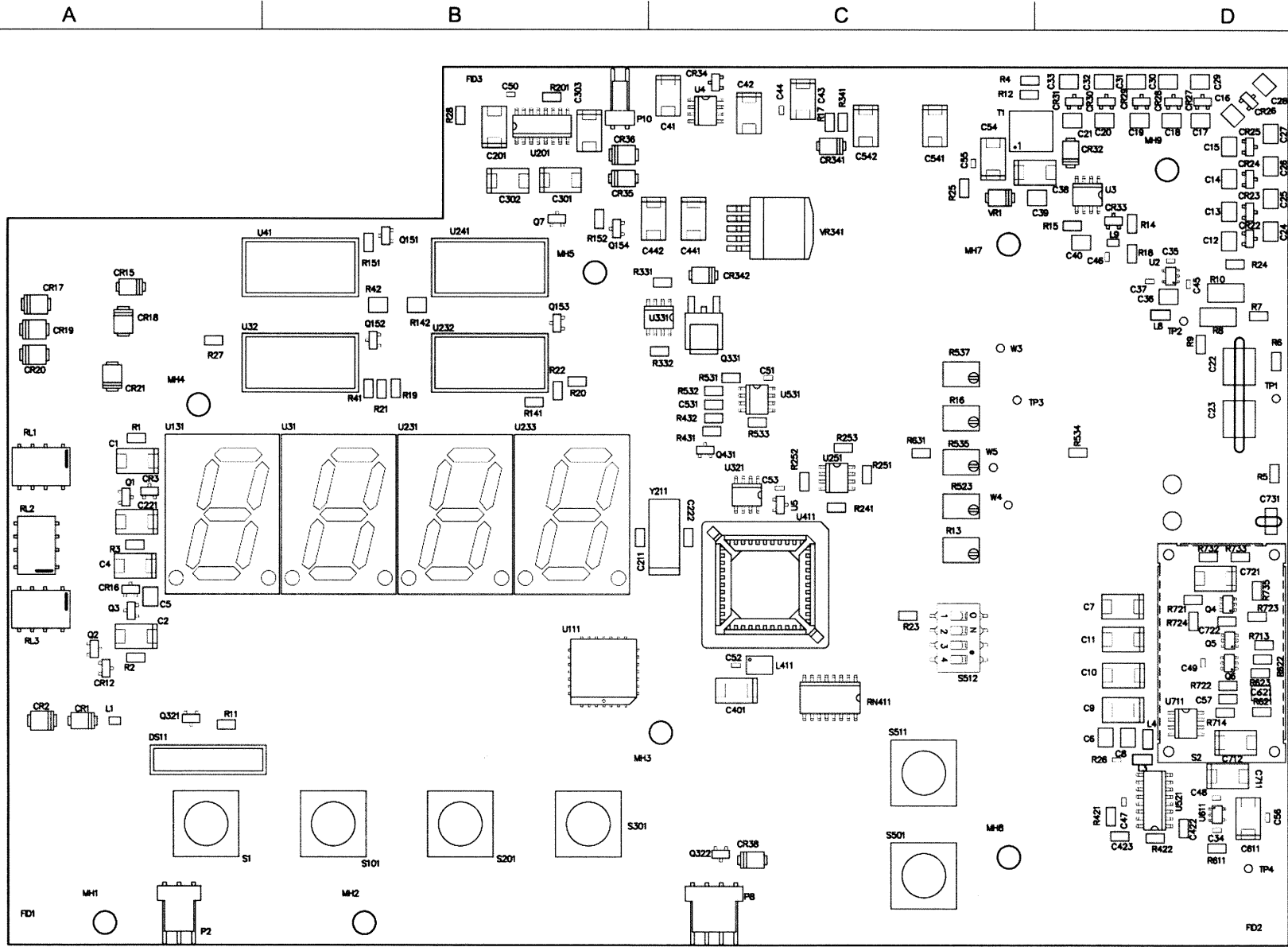

<b>LUDLUM</b>		PO Box 810	
MEASUREMENTS, INC.		501 Oak Street	
		Sweetwater, Texas 79556	
		U.S.A. 1-800-622-0828	
Drawn: PAB	12/14/2022	Title: MAIN BOARD (2022)	
Design: RSS	12/14/2022	Model: 375	
Approved: [Signature]		Board#: 5558-545	
Print Date: 12/14/2023 12:19 AM	Sheet: 5 of 5	Series	Sheet
	Rev: 1	558	545
Sheets: [Signature] [Signature]			

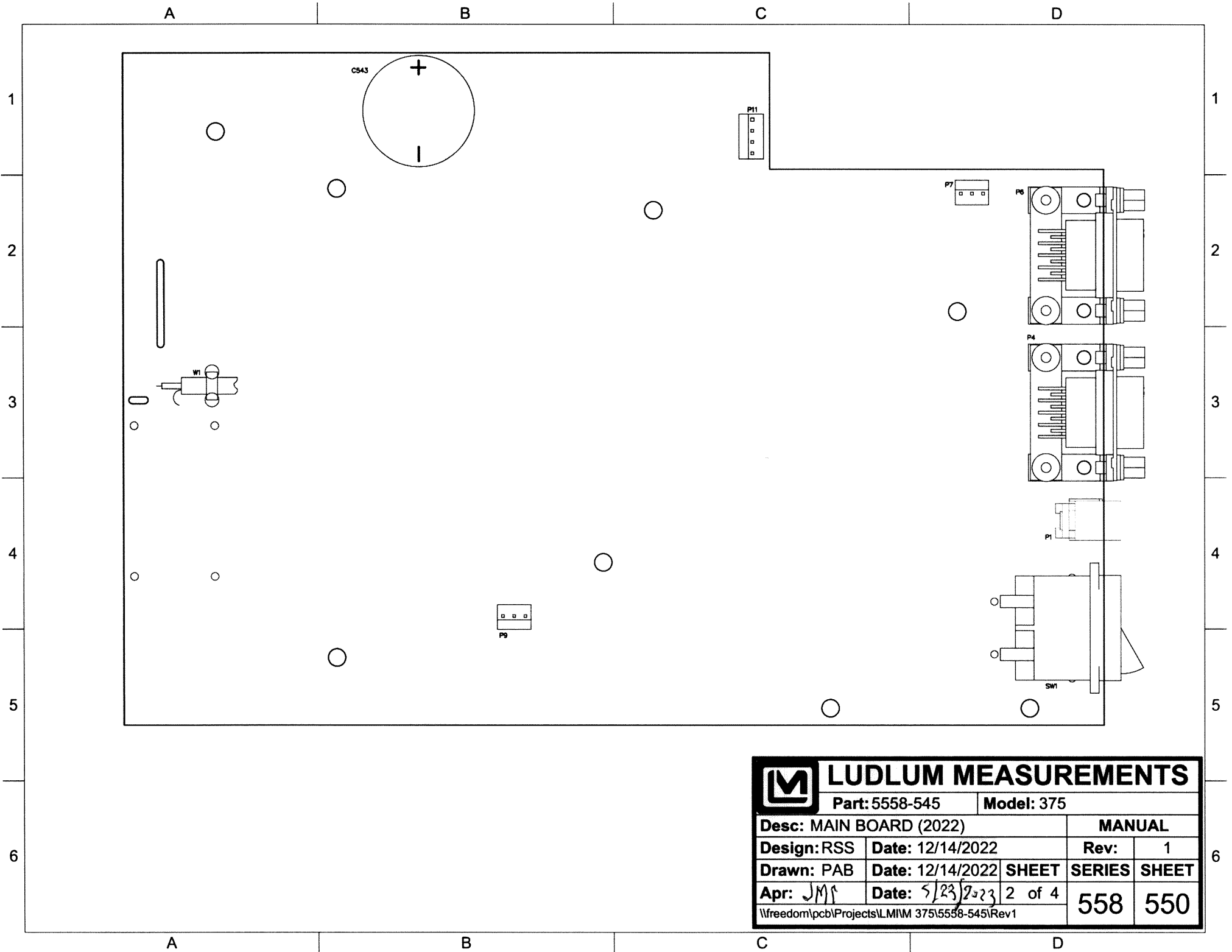

 <b>LUDLUM MEASUREMENTS</b>				
				Part: 5558-545
Desc: MAIN BOARD (2022)			MANUAL	
Design: RSS	Date: 12/14/2022		Rev:	1
Drawn: PAB	Date: 12/14/2022	SHEET	SERIES	SHEET
Apr: JMC	Date: 5/23/2023	1 of 4		
\\freedom\pcb\Projects\L\MIM 375\5558-545\Rev1			558	550



 <b>LUDLUM MEASUREMENTS</b>				Part: 5558-545		Model: 375	
				Desc: MAIN BOARD (2022)			
Design: RSS		Date: 12/14/2022		Rev:	1		6
Drawn: PAB		Date: 12/14/2022	SHEET	SERIES	SHEET		
Apr: JMS	Date: 5/23/2023	2 of 4		558	550		
\\freedom\pcb\Projects\LMIM 375\5558-545\Rev1							

OPTIONAL  
FORM C RELAY (3 PIN CONNECTOR ADDED)

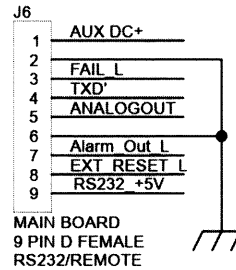
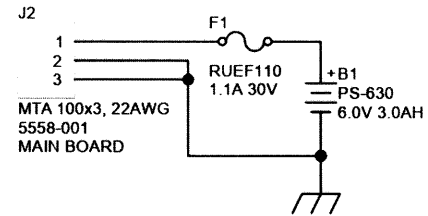
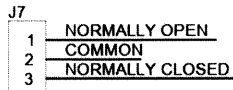

OPTIONAL ALARM SIGNAL

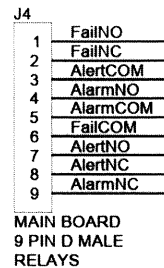
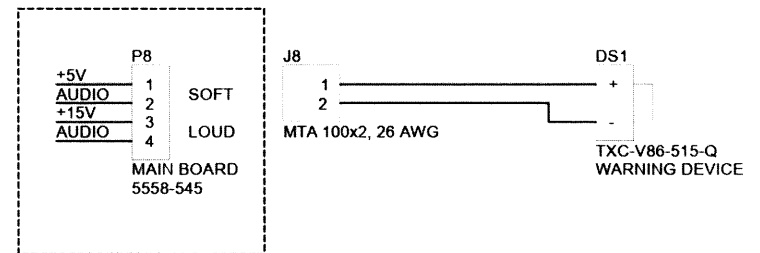
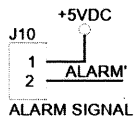

\* Relay pinouts describe Energized  
"Normally ON" Positions.

OPTIONAL RECORDER OUTPUT

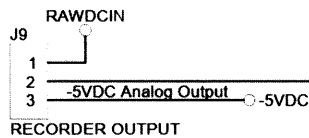

		PO Box 810 501 Oak Street Sweetwater, Texas 79556 U.S.A. 1-800-622-0828	
Drawn: PAB	5/24/2023	Title: WIRING DIAGRAM	
Design: RSS	5/24/2023	Model: 375	
		Board#: 558-136	
Approved: <i>RDS</i>	<i>24 May 23</i>	Sheet: 1 of 1	Series
Print Date: 5/24/2023 1:03:47 PM	Rev: 2		Sheet 136
\\freedom\pcb\Projects\LM\MM 375\558-136\REV2\558136R2P1_SchDoc			



## Ethernet Network Settings

### for Model 375 Series, 375P, and 4525/4530

This appendix describes how to configure the network settings for a 375 Series, 3276, 4525, or 4530 that has been configured for Ethernet using the new ESP32 Ethernet board. Ethernet boards using the Rabbit Ethernet chip do not support all the features described below.

Part Number	Description
<b>4396-579</b>	Model 375 Ethernet Hardware Kit
<b>4498-958</b>	Model 3276 Ethernet Hardware Kit
<b>4511-954-01</b>	Model 4525-5000 Main Module Ethernet Kit
<b>4517-540</b>	Model 4530 Parts Kit
<b>4558-566</b>	Model 375 Ethernet Option
<b>4558-567</b>	Model 375 Legacy Ethernet Option
<b>4557-616</b>	Model 375 Legacy ESP32-POE Assembly/Mount Board
<b>4558-617</b>	Model 375 ESP32-POE Assembly/Mount Board
<b>4558-618</b>	Model 4525 ESP-POE Assembly/Mount Board
<b>5396-565</b>	Model 4525 Main Board
<b>5558-536</b>	Model 4530 Main Board

## Modes of Operation

The new firmware in the Ethernet kit supports all the instruments above using a single firmware version. The three different modes are:

1. Model 375 TCP – Compatible with the Model 375 Webpage and Universal software.
2. Model 375 UDP – Compatible with the Model 375 Ethernet software.
3. Model 4525 – Compatible with the Model 4525/4530.

The mode can be changed by selecting the radio button at the top of the network settings page and saving. The mode must be saved first before the corresponding parameters are shown.

**NOTE:**

It is no longer necessary to have custom firmware on the 375 main board to support Ethernet software using the 375 UDP mode. The UDP port and unit ID are now handled by the Ethernet board. If the firmware is already installed, those settings will be ignored in favor of the settings on the Ethernet board.

### Finding the Instruments on the Network

The instruments can be found by launching the Device Finder utility.

This can be downloaded from our website here:

<https://ludlums.com/software/DeviceFinder.zip>

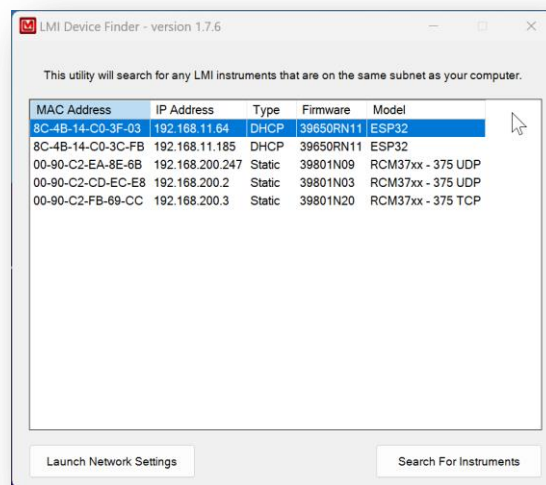

Device Finder will search the local subnet for any instruments on the network using a UDP broadcast message on UDP port 20034. This port must be opened on the computer running the utility for it to find any instruments.

The MAC address, IP address, Type (DHCP or Static), Firmware versions, and Model will be displayed.

#### MAC Addresses

MAC Address	Description
00-90-C2 or 00-C0-33	Rabbit RCM37xx (Obsolete)
8C-4B-14 or 08-3A-AF	ESP32 (New Board)



To open the instrument's network settings page, select the instrument from the list and click **Launch Network Settings**. This will open the default web browser to the IP address of the instrument. You can also type in the IP address into a web browser directly to access the network settings page.

**NOTE:**

RCM37xx – 375 UDP does not have a network settings page.

If an instrument does not show up in the list or was added to the network after the search was completed, click the **Search for Instruments** button to perform another search.

## Network Settings

Using either the Device Finder app or typing the IP address directly into a web browser will open the Network Settings page of the Ethernet board. Depending on the current mode of operation, the network settings page will display different parameters. The modes will all have some common parameters such as serial number and network settings. Before the applicable settings are displayed, the mode must be changed using the password and Submit button.

### Model 375 Network Settings

375 TCP Mode   
  375 UDP Mode   
  4525 Mode  
When changing to 4525 mode, IP address will change to 192.168.200.1

<b>Connection Status</b>	Connected to Supervisor	
<b>Current Reading</b>	0027.0 cpm	
<b>Firmware Version</b>	39650RN11	
<b>MAC Address</b>	8C-4B-14-C0-3C-FB	
<b>Last Updated</b>	4/19/2023, 4:41:58 PM	

<b>Serial Number</b>	<input type="text" value="325496"/>	Serial number of device (000000 - 999999)
<b>Unit Code</b>	<input type="text" value="cpm"/>	Units of device

Use DHCP   
  Use Static Address  
When changing between DHCP and static IP address, the setting must be saved first before the network settings can be changed.

<b>IP Address</b>	<input type="text" value="192.168.11.185"/>	IP address of device
<b>Subnet Mask</b>	<input type="text" value="255.255.0.0"/>	Subnet mask IP address of device
<b>Gateway</b>	<input type="text" value="192.168.0.1"/>	Gateway IP address of device (automatically set for DHCP)
<b>DNS</b>	<input type="text" value="192.168.0.71"/>	DNS IP address of device (automatically set for DHCP)
<b>TCP/IP Port</b>	<input type="text" value="50001"/>	Port number of Supervisor service (0-65535)
<b>Supervisor IP Address</b>	<input type="text" value="10.0.0.50"/>	IP address that device will use to attempt to connect to the Supervisor service

If you wish to change any of the above settings, simply enter the correct password in the "Password" text box, then click on the "Submit" button.

If you wish to change the password, enter the current password in the "Password" text box and the new password in the "New Password" and the "Confirm New Password" text boxes, then click on the "Submit" button.

Ludlum Measurements, Inc.  
 501 Oak Street  
 Sweetwater, TX 79556  
 (325) 235-5494  
 (800) 622-0828  
[www.ludlum.com](http://www.ludlum.com)

Figure 1 - 375 TCP Mode

### Model 375 Network Settings

375 TCP Mode   
  375 UDP Mode   
  4525 Mode  
When changing to 4525 mode, IP address will change to 192.168.200.1

<b>Current Reading</b>	0028.0 cpm	
<b>Firmware Version</b>	39650RN11	
<b>MAC Address</b>	8C-4B-14-C0-3C-FB	
<b>Last Updated</b>	4/19/2023, 4:45:51 PM	

<b>Serial Number</b>	<input type="text" value="325496"/>	Serial number of device (000000 - 999999)
<b>Unit Code</b>	<input type="text" value="cpm"/>	Units of device

Use DHCP   
  Use Static Address  
When changing between DHCP and static IP address, the setting must be saved first before the network settings can be changed.

<b>IP Address</b>	<input type="text" value="192.168.11.185"/>	IP address of device
<b>Subnet Mask</b>	<input type="text" value="255.255.0.0"/>	Subnet mask IP address of device
<b>Gateway</b>	<input type="text" value="192.168.0.1"/>	Gateway IP address of device (automatically set for DHCP)
<b>DNS</b>	<input type="text" value="192.168.0.71"/>	DNS IP address of device (automatically set for DHCP)
<b>UDP Port</b>	<input type="text" value="50000"/>	UDP Port number to broadcast UDP Messages (50000-59999)
<b>Unit ID</b>	<input type="text" value="1"/>	Unit ID of M375 (1-255)

If you wish to change any of the above settings, simply enter the correct password in the "Password" text box, then click on the "Submit" button.

If you wish to change the password, enter the current password in the "Password" text box and the new password in the "New Password" and the "Confirm New Password" text boxes, then click on the "Submit" button.

Ludlum Measurements, Inc.  
 501 Oak Street  
 Sweetwater, TX 79556  
 (325) 235-5494  
 (800) 622-0828  
[www.ludlum.com](http://www.ludlum.com)

Figure 2 - 375 UDP Mode

Figure 3 - 4525 Mode

## Common Settings

The following settings are common to all operating modes.

**DHCP/Static IP Address** – These two radio buttons determine if the IP address and other network settings are set statically (Manually Assigned) or automatically through DHCP. When set to DHCP, the network settings shown are the values set by DHCP. To set the network settings manually, click the Use Static IP address radio button and fill in the appropriate values for the network settings.

When in DHCP mode, if the radiation monitor cannot get an IP address automatically, it will fall back to an IP address in the 169.254.x.x range.

**Serial Number** – This is the serial number stamped on the front of the instrument or on a sticker.

**IP Address** – An IP address is a unique IPV4 address assigned to each device on the network. It can be assigned manually or dynamically through DHCP.

**Subnet Mask** - A subnet mask is a 32-bit number created by setting host bits to all 0s and setting network bits to all 1s. In this way, the

subnet mask separates the IP address into the network and host addresses.

**Gateway** – The Default Gateway IP address is the device that allows access to servers that are outside of the network.

**DNS** – The DNS IP address is the server that is responsible for converting human readable names into IP addresses.

## Password Settings

To save settings, the correct password must be entered into the Password field. By default, the password is “password.” To change the password, enter the new password in the New Password field and retype it in the Confirm New Password field. Then enter the current password and click the Submit button.

## Model 375 TCP Mode

The TCP mode sends data to a user-defined IP address and user-defined TCP port number. This mode is compatible with both the 375 Webpage and Universal software. The following settings can be set in this mode.

**Unit Code** – Set the display units reported to the software. This must match the label on the front of the instrument. Choices are:  $\mu$ R/hr, mR/hr, R/hr,  $\mu$ Sv/hr, mSv/hr, Sv/hr,  $\mu$ rem/hr, mrem/hr, rem/hr, cpm, cps, kcpm, and kcps.

**TCP/IP Port** – Sets the port number that the Supervisor computer is listening on. The default is 50000 but can be adjusted from 50000 to 59999.

**Supervisor IP Address** – Sets the IP address that the instrument will connect to. This is the computer running the Windows service of the Webpage or Universal software.

The data is sent every two seconds in the following format:

```
<?xml version="1.0" encoding="us-ascii" ?>
<area_monitor rev="1.0" serial="12345">
  <status>
    <rate>9999.9</rate>
    <units_code>99</units_code>
```

```
<audio>1</audio>
<alarm1>1</alarm1>
<alarm2>1</alarm2>
<over_range>1</over_range>
<monitor>1</monitor>
<error_code>9</error_code>
</status>
</area_monitor>
```

The data has been formatted here to show the structure more easily. The actual data does not have line breaks after each section and is one continuous line.

## Model 375 UDP Mode

The UDP mode sends data to a user-defined UDP port number. This mode is compatible with the Model 375 Ethernet software. The data are sent using a broadcast IP Address of 255.255.255.255. Any device on the same subnet will be able to see the data on the correct UDP port number. The following settings can be set in this mode.

**Unit Code** – Set the display units reported to the software. This must match the label on the front of the instrument. Choices are:  $\mu\text{R/hr}$ ,  $\text{mR/hr}$ ,  $\text{R/hr}$ ,  $\mu\text{Sv/hr}$ ,  $\text{mSv/hr}$ ,  $\text{Sv/hr}$ ,  $\mu\text{rem/hr}$ ,  $\text{mrem/hr}$ ,  $\text{rem/hr}$ ,  $\text{cpm}$ ,  $\text{cps}$ ,  $\text{kcpm}$ , and  $\text{kcps}$ .

**UDP Port** – Sets the UDP port that the data will be broadcasted. This is adjustable from 50000 to 59999.

**Unit ID** – This is a unique ID number assigned to each instrument on the network. Typically instrument one is assigned a unit ID of 1, the next one is 2, etc.

### NOTE:

Previous versions of the Ethernet board required a special firmware to be installed in the Model 375 to be able to set the unit ID and UDP port. On the newer versions, this is set here in the network settings page, so no special firmware is required. If the instrument has the special firmware, the unit ID and UDP port are ignored, instead using the values set on the network settings page.

The data is formatted as a string, very much like the standard RS-232 data output. See below:

```

Byte 1      L
Byte 2      M
Byte 3      I
Byte 4      0          x
Byte 5      x          x
Byte 6      x      OR  x
Byte 7      x          x
Byte 8      .          .
Byte 9      x          0
Byte 10     Audio Status = 1 = on
Byte 11     Alarm Status = 1 = on
Byte 12     Alert Status = 1 = on
Byte 13     Over Range Status = 1 = on
Byte 14     Monitor Status = 1 = on
Byte 15     Error Code
Byte 16     UNIT ID CHAR 1
Byte 17     UNIT ID CHAR 2
Byte 18     UNIT ID CHAR 3
Byte 19     PORT NUM CHAR 1
Byte 20     PORT NUM CHAR 2
Byte 21     PORT NUM CHAR 3
Byte 22     PORT NUM CHAR 4
Byte 23     3          Firmware version of Model 375|
Byte 24     9
Byte 25     6
Byte 26     x
Byte 27     x
Byte 28     n
Byte 29     x
Byte 30     x
Byte 31     3          Firmware version of Ethernet board
Byte 32     9          Note: The firmware version of the
Byte 33     8          Ethernet board is not sent out the
Byte 34     x          serial port of the Model 375!
Byte 35     x
Byte 36     n
Byte 37     x
Byte 38     x
Byte 39     Carriage Return (0DH)
Byte 40     Line Feed (0AH)

```

If the firmware in the instrument is standard, then the values for the instrument firmware in the data output will all be the letter “X.”

## Model 4525 Mode

The Model 4525 mode is compatible with both the 4525 and 4530 gate monitors. The Ethernet board waits for a connection from the Supervisor computer on TCP port 23. Once the connection is established, it begins passing data back and forth from the Supervisor computer and the gate monitor’s serial port.