

LUDLUM MODEL 43-10
ALPHA SAMPLE COUNTER
February 2018

LUDLUM MODEL 43-10
ALPHA SAMPLE COUNTER
February 2018



LUDLUM MEASUREMENTS, INC
501 OAK STREET, P.O. BOX 810
SWEETWATER, TEXAS 79556
325-235-5494, FAX: 325-235-4672

STATEMENT OF WARRANTY

Ludlum Measurements, Inc. warrants the products covered in this manual to be free of defects due to workmanship, material, and design for a period of twelve months from the date of delivery. The calibration of a product is warranted to be within its specified accuracy limits at the time of shipment. In the event of instrument failure, notify Ludlum Measurements to determine if repair, recalibration, or replacement is required.

This warranty excludes the replacement of photomultiplier tubes, G-M and proportional tubes, and scintillation crystals which are broken due to excessive physical abuse or used for purposes other than intended.

There are no warranties, express or implied, including without limitation any implied warranty of merchantability or fitness, which extend beyond the description of the face thereof. If the product does not perform as warranted herein, purchaser's sole remedy shall be repair or replacement, at the option of Ludlum Measurements. In no event will Ludlum Measurements be liable for damages, lost revenue, lost wages, or any other incidental or consequential damages, arising from the purchase, use, or inability to use product.

RETURN OF GOODS TO MANUFACTURER

If equipment needs to be returned to Ludlum Measurements, Inc. for repair or calibration, please send to the address below. All shipments should include documentation containing return shipping address, customer name, telephone number, description of service requested, and all other necessary information. Your cooperation will expedite the return of your equipment.

**LUDLUM MEASUREMENTS, INC.
ATTN: REPAIR DEPARTMENT
501 OAK STREET
SWEETWATER, TX 79556**

**800-622-0828 325-235-5494
FAX 325-235-4672**

Model 43-10 Alpha Sample Counter
February 2018



TABLE OF CONTENTS

1. GENERAL	1
2. SPECIFICATIONS	1
3. OPERATING PROCEDURES	1
4. CALIBRATION	2
4.1 Counting Instrument	2
4.2 Procedure	2
5. TROUBLESHOOTING	3
5.1 Zero or Very Low Counts	3
5.2 No Source Plateau	3
5.3 Excessive Background Count	3
PARTS LIST	4
DRAWINGS AND DIAGRAMS	6

Model 43-10 Alpha Sample Counter

February 2018

1. GENERAL

The Model 43-10 is a windowless alpha sample changer for counting filters or planchets. The sample changer can be used with any of the Ludlum scaler instruments or other equivalent counting instruments.

The sample drawer, when fully closed, strikes a microswitch to allow high voltage (HV) to

be applied to the photomultiplier tube (PMT). The sample drawer is locked in the closed position by rotation of the slide lever mounted on the side of the instrument.

The scintillator material ZnS (Ag) is attached to the light pipe.

2. SPECIFICATIONS

SCALER INPUT SENSITIVITY: 2-500 mV

PHOTOMULTIPLIER TUBE: 5.1 cm (2 in.) diameter, 14 pin tube base, 10 pin dynode structure

SCINTILLATOR MATERIAL: ZnS disc; plastic 0.025 cm (0.01 in.) thick

SAMPLE HOLDER: 50.8 x 4.4 mm (2 x 0.175 in.) (Dia x L) and 28.3 x 4.4 mm (1.115 x 0.175 in.) (Dia x L)

MAXIMUM SAMPLE SIZE: 56.9 mm diameter x 10.8 mm thick (2.4 x 0.428 in.)

HV SWITCH: opening sample slide disables PMT high voltage

DETECTOR OPERATING VOLTAGE: 500-1200 V

DYNODE STRING RESISTANCE: 60 Megohm

EFFICIENCY (4 π): 37% for ²³⁹Pu

CONNECTOR: Series "C" (others available)

TEMPERATURE RANGE: -20 to 50 °C (-4 to 122 °F). May be certified for operation from -40 to 65 °C (-40 to 150 °F).

SIZE: 23.6 x 11.4 x 23.6 cm (9.3 x 4.5 x 9.3 in.) (H x W x L)

WEIGHT: 1.9 kg (4.1 lb)

CONSTRUCTION: aluminum housing with beige powder coat

3. OPERATING PROCEDURES

Connect the Model 43-10 to the scaler counting instrument. The coax cable with "C" connectors carries both the signal and HV.

HV is applied to the photomultiplier tube (PMT) when the sample slide is pushed completely in, tripping the microswitch. Rotate the sample slide lever to the locked

position, securing the sample slide in the "ON" position.

Select appropriate count time and record the background counts. Approximately 3 cpm can be expected as normal background activity.

For counting source material, place the source material on the appropriate side of

Model 43-10 Alpha Sample Counter

February 2018

the sample holder for the 2.5 or 5.1 centimeters (one or two-inch) filters. Do not allow the source material to extend above the top of the sample slide. For optimum performance, place the sample slide in the locked position for a short time before taking count to allow room light to decay

out of the scintillation material.

A background count should be taken after each source count to check for contamination on the sample holder or area within the O-ring.

4. CALIBRATION

4.1 Counting Instrument

- Calibrated scaler instrument
- Detector operating voltage 500–1200 V
- Input sensitivity 2 mV to 500 mV

NOTE: The Model 43-10 should be dark-adapted, slide-closed, and locked a minimum of two hours after assembly before taking data.

4.2 Procedure

Background Check

- Connect the Model 43-10 to the counting instrument using the proper cable.
- Close and lock the sample drawer.
- Record background count starting at 500 volts. Increase voltage in 50-volt increments until the background count exceeds 3 cpm. Do not exceed 1500 volts.

Source Plateau

- Place the check source in the sample drawer. Close and lock the drawer. Raise the source from the bottom of the sample drawer if the thickness of the source permits, for better

counting geometry.

- Record sample count starting at 500 V with 50-volt increments until 3 cpm background voltage is determined in the third step of the background check.
- Set the HV just above the knee of the plateau. Background count should be ≤ 3 cpm at that operating point.

Determining Efficiency

- Calibrated check source required.
- Source may be in counts per minute (cpm), disintegrations per minute (dpm), or microcuries (μCi).
- Cpm source: Position the source for the best geometry in the sample drawer.
- Set HV as determined in the source plateau section (third step).
- Record the source count. Divide the source count by the calibrated cpm source and multiply by 100 for % efficiency (2π).
- DPM source: Position the source for the best geometry in the sample drawer.
- Record the source count. Divide the source count by the calibrated dpm source and multiply by 100 for % efficiency (4π).
- To calculate dpm from a microcurie source, change microcuries to dpm equivalent and calculate efficiency by recording the source count divided by the calibrated dpm source, multiplied by 100 for 4π efficiency. (1 microcurie is equal to 2.22×10^6 dpm.)

5. TROUBLESHOOTING

5.1 Zero or Very Low Counts

- Large light leak
- PMT malfunction
- Broken wire in tube socket
- Inoperative HV switch on sample counter or broken wire
- Counting instrument malfunction
- Cable malfunction

5.2 No Source Plateau

- Light leak, slide not sealed properly against true base
- Noisy PMT
- Noisy HV switch
- Poor PMT to scintillation light pipe interface

5.3 Excessive Background Count

- Light leak
- PMT malfunction
- Cable malfunction
- Noisy HV switch
- Instrument contaminated

Model 43-10 Alpha Sample Counter
February 2018

PARTS LIST

Reference Number	Description	Part No.
------------------	-------------	----------

Model 43-10 Alpha Sample Counter

UNIT	Completely Assembled 43-10 Alpha Sample Counter	47-1526
------	---	---------

Voltage Divider Board, Drawing 435 x 964

BOARD	Assembled Voltage Divider	5435-401
-------	---------------------------	----------

C11	• CAPACITORS	
	0.01mF, 2kV, C	04-5722

R1-R12	• RESISTORS	
	4.75 Megohm, χ W, 1%	12-7995

Switch Filter Board, Drawing 142 x 58

BOARD	Assembled Switch Filter	5412-103
-------	-------------------------	----------

C1-C2	• CAPACITORS	
	CAP 0.0047 μ F, 3kV, C	04-5547
C3	CAP 0.0015 μ F, 3kV, C	04-5518

R1-R2	• RESISTORS	
	RES-1 Megohm, $\frac{1}{4}$ W, 5%	10-7028

Assembly View, Drawing 142 x 31B

*	PM TUBE- 5.1 cm (2-inch) B51D01W	01-5919
*	TUBE HOLDER AND BASE: Model 43-10	2142-002-02
*	BASE: Model 43-10	7142-002-04
*	TUBE: Model 43-10	7142-015
*	CONNECTOR CAP: Model 43-10	7142-014
*	SAMPLE DRAWER: Model 43-10, Model 43-17	7142-001-06
*	ACRYLIC DISC WITH ZnS	4142-074
2EA.	SPACER STRIP .015	7142-002-03
*	ADAPTOR PLATE: Model 43-10	7142-003-01
*	BRACKET: Model 43-10	7142-004-01
*	CAP: Model 43-10	7142-004-02
*	CASE TOP: Model 43-10	7142-004-03
*	CASE BOTTOM: Model 43-10	7142-004-04
*	CAP GASKET: Model 43-10	7142-017
*	BASE PLATE: Model 43-10, Model 43-17	7142-018
*	SHAFT: Model 43-10, Model 43-17	7142-019
*	LIFTER: Model 43-10, Model 43-17	7142-020
*	PIN: Model 43-10, Model 43-17	7142-021
2 EA,	SPACER STRIP .010	7142-232
3EA.	5.1 cm (2-inch) CRYSTAL FOAM PAD	7260-001-05
10 EA.	PLANCHETTE-2 x 1/8 in.	7252-371A

**Model 43-10 Alpha Sample Counter
February 2018**

Reference Number	Description	Part No.
*	PLANCHET HOLDER	7142-001-07
*	SWITCH-BZ-2RD-A2 MICRO	08-6538
*	KNOB-90 4 2G POINTER	08-6608
P1	RECEPTACLE: UG706/U	4478-011
4EA.	BUMPER-3M	21-9376

**Model 43-10 Alpha Sample Counter
February 2018**

DRAWINGS AND DIAGRAMS

Assembly View, Drawing 142 x 31B

Voltage Divider Board, Drawing 435 x 964

Voltage Divider Board Component Layout, Drawing 435 x 965

Switch Filter Board, Drawing 142 x 58

Switch Filter Board Component Layout, Drawing 142 x 59

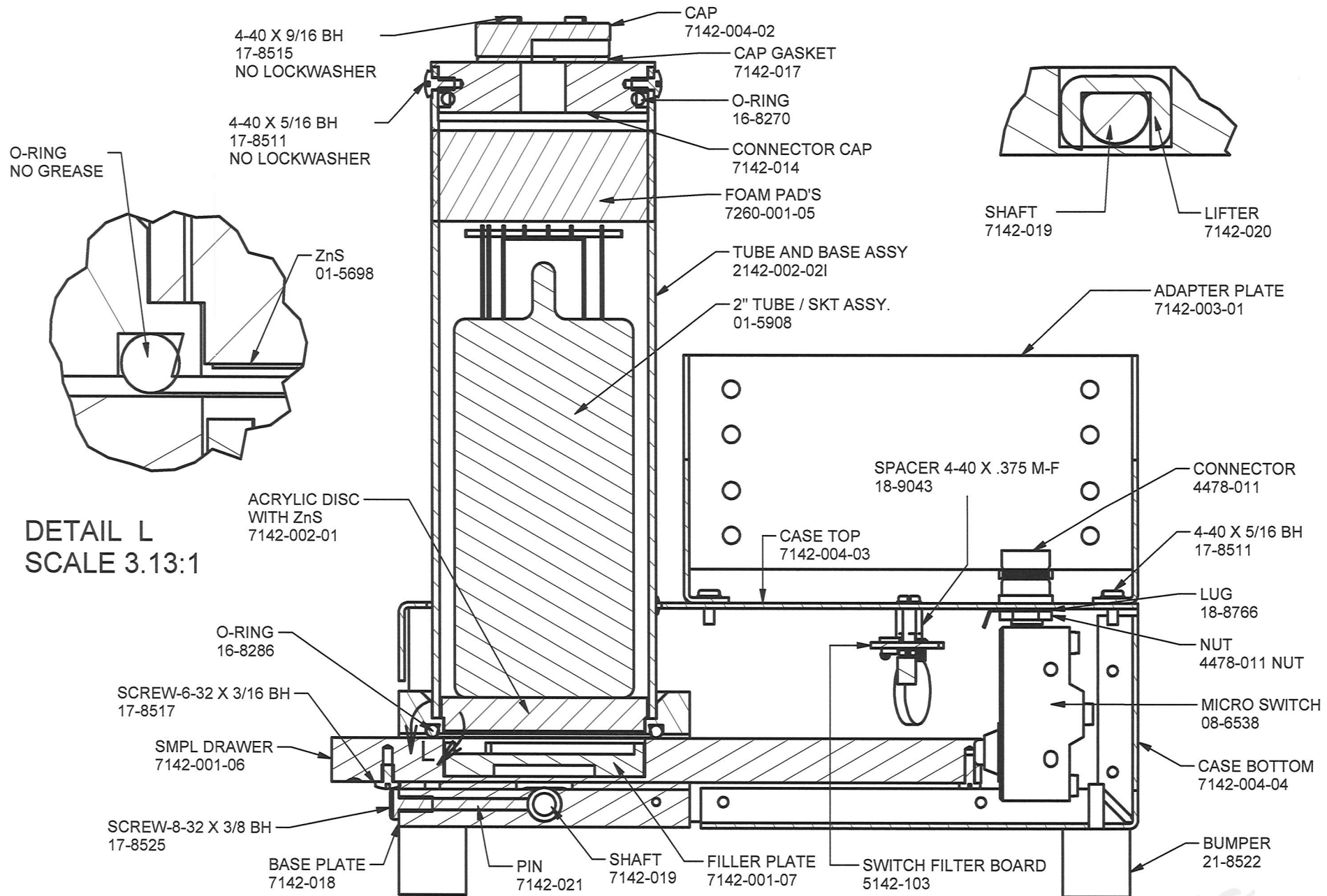

DETAIL L
SCALE 3.13:1

REVISION HISTORY

REV	DESCRIPTION	DATE	BY
2	ECF # 802	06/29/98	DDW
3	ECF # 1072	10/31/01	DSW
4	REDRAWN ON COMPUTER	05/23/2012	ADG
5	PLACED LOCKWASHERS	1/3/18	ZSZ

DWN ZSZ	DATE 1/3/18	CHK	DATE	APP	DATE
DWG NUM: 4142-043				SCALE: 1:2	
TITLE M 43-10					
LUDLUM MEASUREMENTS, INC. 501 OAK STREET SWEETWATER, TEXAS 79556			SERIES 142	SHEET 31B	

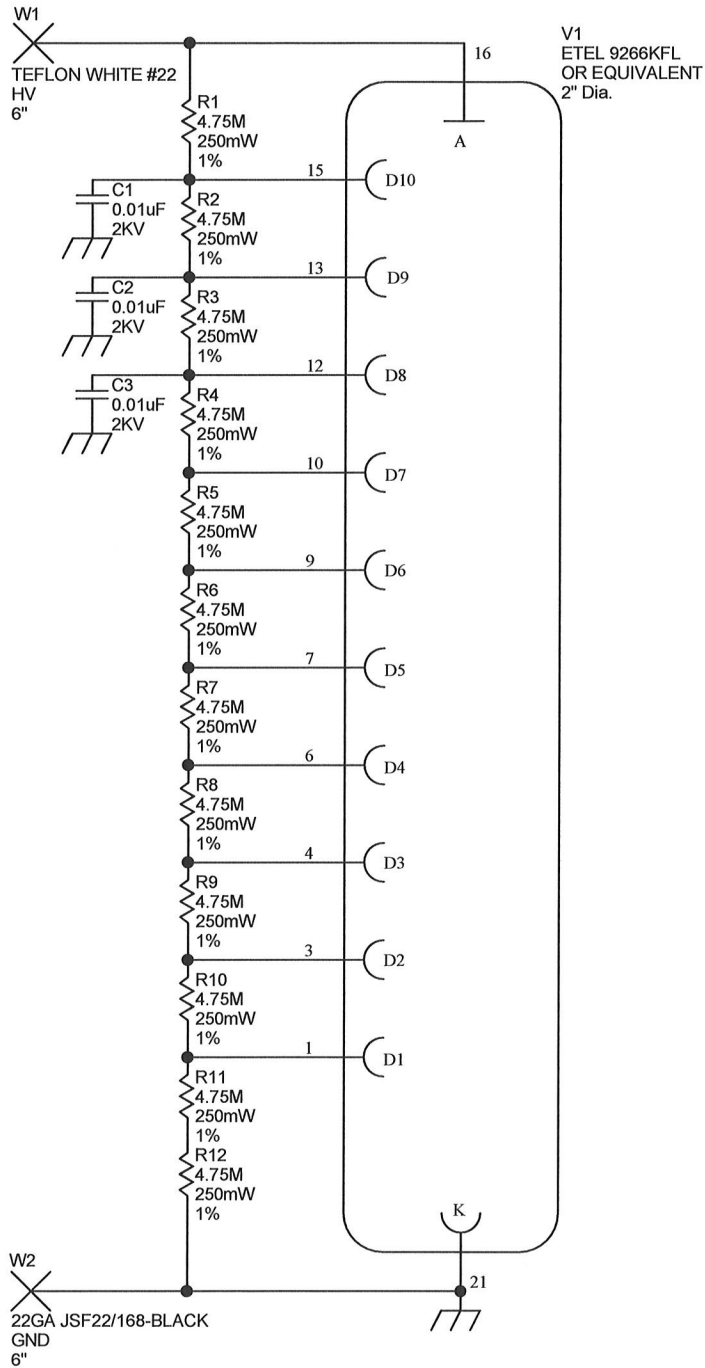

		LUDLUM		PO Box 810	
		MEASUREMENTS, INC.		501 Oak Street	
				Sweetwater, Texas 79556	
				U.S.A. 1-800-622-0828	
Drawn: AC	05/07/2012	Title: VOLTAGE DIVIDER			
Design: RSS	05/07/2012	Model: VARIOUS			
		Board#: 5435-401			
Approve: <i>J.W.</i>	<i>10-22-12</i>	Sheet: 1 of 1		Series	Sheet
Print Date: 10/10/2012	9:37:50 AM	Rev: 2		435	964
W:\Projects\LMI\VoltageDividers\5435-401\Rev2\435401R2P1.SchDoc					

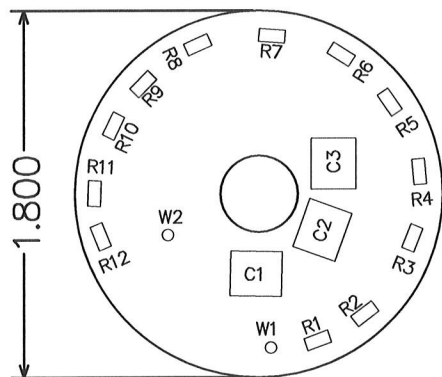

LUDLUM
MEASUREMENTS, INC.

PO Box 810
501 Oak Street
Sweetwater, TX 79556
U.S.A. 1-800-622-0828

Title: VOLTAGE DIVIDER				
Drawn: AC	05/07/2012	Model: VARIOUS		
Design: RSS	05/07/2012	Board#: 5435-401		
Approve: <i>AW</i>	<i>10-22-12</i>	Rev: 2		
Print Date:		SCALE: 1.00	Series	Sheet
10/10/2012	9:37:52 AM	Top Overlay	435	965
W:\Projects\LMIVoltageDividers\5435-401\Rev2\435401R2_Manual.PcbDoc				

REVISIONS						
EFF	AUTHORITY	ZONE	LTR	DESCRIPTION	DATE	APPROVED

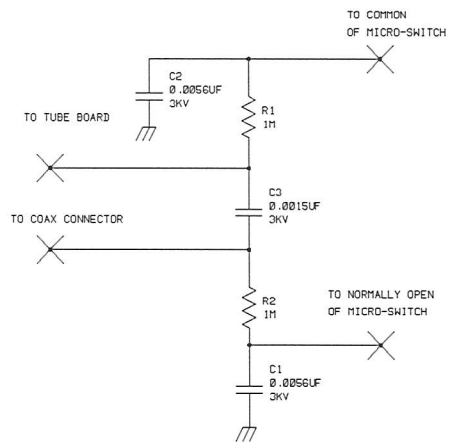

UPDATED	-	LUDLUM MEASUREMENTS INC.			
DR PW	10/20/92	TITLE: SWITCH FILTER BOARD			
CHK	CKB 27-JAN-99				
DSCN PW	10/20/92	BOARD# 5142-103			
APPD	ESS 11-6-01	SIZE	MODEL	SERIES	SHEET
NEXT HIGHER ASSY.	-	C	43-10	142	58
08:36:53	27-Jan-99	58142103	SHEET 1 OF 1		

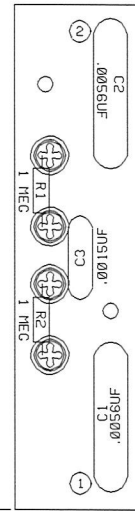

LUDLUM MEASUREMENTS INC. SWEETWATER, TX.			
DR	PW	10/20/92	TITLE: SWITCH
CHK	CKR	27-JAN-99	FILTER BOARD
DSCN	PW	10/20/92	BOARD# S142-103
APP	CS	1-27-99	BS142103
07:28:59	27-Jan-99	MODEL 43-10	SERIES 142
COMP PASTE	COMP MASK	SLDR PASTE	SHEET 59
			S9
			OUTLINE